

# VF940-T Series

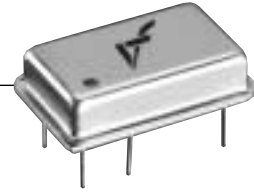

## HCMOS/TTL Compatible Tristate VCXO

### FEATURES

- Fundamental Crystal Design
- Hermetically Sealed Package
- Wide Pulling Range
- Low Cost

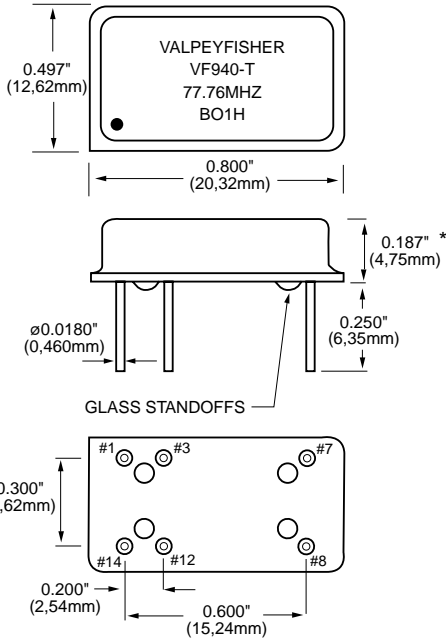

All dimensions are typical unless otherwise specified.  
\*Wide APR may require taller pkg.

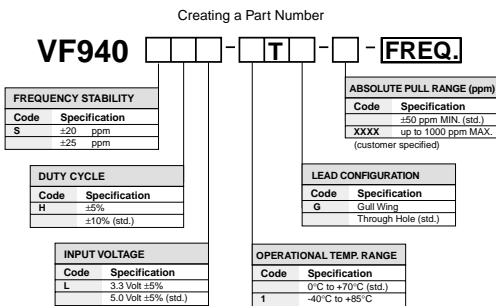

Example: VF940H-1TG-75-77.76MHz; Frequency Stability ±25ppm; Duty Cycle ±5%; Input Voltage 5.0 Volt ±5%; Operating Temperature -40°C to +85°C; Tristate, Gull Wing, APR ±75ppm, Frequency 77.76MHz.

Parameter	Symb	Condition	Min	Typ	Max	Unit	Note	
Absolute Max. Ratings	Input Break Down Voltage	Vcc	-0.5		7.0	V		
	Storage Temp.	Ts	-40		+85	°C		
	Control Voltage	Vc	-1		9	V		
Electrical	Frequency Range	F	1.54		200	MHz		
	Frequency Stability	ΔF/F	vs. Temp., Vcc			±25	ppm	
	Input Voltage	Vcc		4.75 3.15	5.00 3.30	5.25 3.45	V	Std. LV opt.
	Input Current	Icc	No load		20		mA	@20MHz
	Load	10 TTL gates or 50pF MAX, AC coupled 50 Ohm termination recommended for F>52MHz						
	Duty Cycle		@1.4V	40	50	60	%	1
	Rise/Fall Time	Tr/Tf	20% to 80%			6 3	ns	F<54MHz F>54MHz
	Logic "1" Level	Voh	Max Load	0.9Vcc				
	Logic "0" Level	Vol	Max Load			0.1Vcc		
	Start-up Time	Ts			2	10	ms	
	Phase Jitter		1σ			1	ps	fj>1KHz
	Modulation BW	fm	@Vc = 2.5V	10			KHz	@-3db
	Input Impedance		fm<10KHz	50			KOhm	
	Absolute Pull Range	APR	Overall	±50			ppm	2
	Deviation Slope		Monotonic, positive		50 75		ppm/V	Vcc = 5.00 Vcc = 3.3V
Linearity					±20	%	3	
Setability (Vc for center freq)	Vc0	@25°C, Fnom.	2.00 1.25	2.50 1.65	3.00 2.05	V	Std. LV opt.	
Tristate Function	Input HIGH (>2.5V) or floating: ACTIVE Input LOW (<0.5V): INFINITE IMPEDANCE							
Environmental and Mechanical	Operating Temperature Range	0°C to +70°C (-40°C to +85°C available)						
	Mechanical Shock	Per MIL-STD-202, Method 213, Cond. E						
	Thermal Shock	Per MIL-STD-883, Method 1011, Cond. A						
	Vibration	Per MIL-STD-883, Method 2007, Cond. A						
	Soldering Conditions	260°C, for 10s, Max.						
Electrical Connections	Hermetic Seal	Leak rate less than 5 x 10 <sup>-8</sup> atm.cc/s of helium						
	Pin Out	Pin #1-Voltage Control Pin #7-Ground, Case Pin #12-N/C			Pin #3-Tristate Control Pin #8-Output Pin #14-Vcc			

Notes:

1. ±5% symmetry available, contact factory for tighter requirements.
2. Up to ±1,000 ppm pull range available at some frequencies.
3. ±10% and ±5% linearly available.

All specifications are subject to change without notice.