

VFOV302

OCXO – STRATUM 2 Compliant

HCMOS / SINEWAVE



Features

- Standard Frequencies: 10MHz, 12.8MHz
- ± 0.1 ppb frequency stability over temperature
- Ultra Low Jitter and Phase Noise

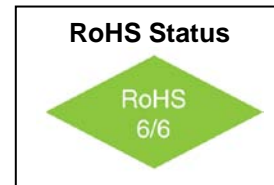

Applications

- Telecommunication Systems
- Rubidium Standard Replacement
- Data Communications
- Stratum II clocking systems

Electrical Specifications

Parameter	Symbol	Condition	Min	Typ	Max	Unit	Note
Frequency Range	F		8.0	10.0	100	MHz	
Frequency Stability	$\Delta F/F$	Vs. Operating Temperature A: 0°C to +50°C			± 0.1	ppb	See "How to Order" Chart
		Vs. Supply Voltage Vs. Aging / Day Vs. Aging / Year After 20 years			± 0.2 ±0.2 ±30 ±0.35	ppb/V ppb ppb ppm	After 30 days. STD option shown see "How to Order"
Temperature Range	T		-40°		+85°	°C	Order Code G
Supply Voltage	Vcc		4.75 11.4	5.0 12.0	5.25 12.6	V	Order Code D Order Code B
Power Consumption	P	Steady State @ 25°C Steady State @ -30°C Start-Up @ -30°C		1.25 2.0 3.5	1.5 2.2 4.0	W	
Output		HCMOS V _H / V _L Sine	3.9 +6	+8	0.4 +10	V dBm	
Load		50 Ohm (Sinewave), 10KOhm / 15pF (HCMOS)					Order Code S Order Code H
Duty Cycle		HCMOS	45		55	%	
Sub-Harmonics		< 30MHz > 30MHz		None	-40	dBc	Fundamental Multiplied
SSB Phase Noise		1Hz 10Hz 100Hz 1KHz 10KHz		-95 -125 -145 -155 -165		dBc/Hz	@ 10MHz



VFOV302 OCXO – STRATUM 2 Compliant HCMOS / SINEWAVE



Parameter	Symbol	Condition	Min	Typ	Max	Unit	Note
Warm up time		To 0.01ppm accuracy		3	5	min	
Retrace		After 30 minutes			± 1.0	ppb	
G-sensitivity		Worst direction			± 1.0	ppb/g	
Control Voltage	V _c		0		4.0	V	
Pullability			± 0.35	± 0.5		ppm	
Deviation slope		Monotonic, positive		0.2		ppm/V	
Reference Output	V _{co}	@25C, F _{nom} .	4.19	4.3	4.41	V	

How to Order

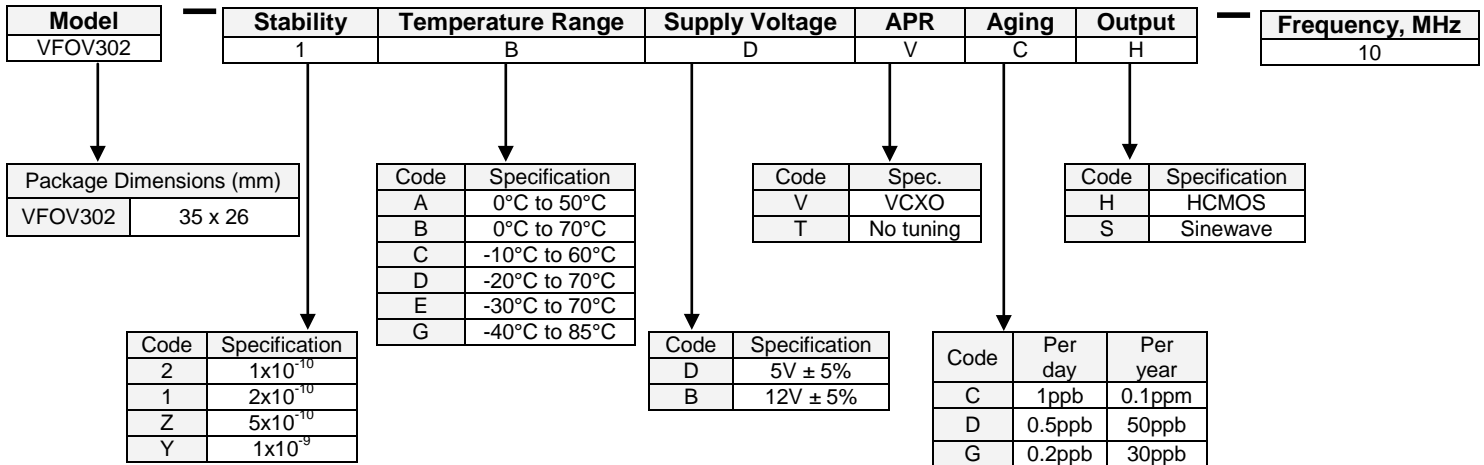

Available Frequency Stabilities over Operating Temperature Ranges

Code	Temperature Range	Stability			
		1x10 ⁻⁹	5x10 ⁻¹⁰	2x10 ⁻¹⁰	1x10 ⁻¹⁰
A	0°C to 50°C	*	*	*	*
C	-10°C to 60°C	*	*	*	*
B	0°C to 70°C	*	*	*	
D	-20°C to 70°C	*	*	*	
E	-30°C to 70°C	*	*		
G	-40°C to 85°C	*	*		



VFOV302

OCXO – STRATUM 2 Compliant

HCMOS / SINEWAVE

Absolute Maximum Ratings

Parameter	Symbol	Condition	Min	Typ	Max	Unit	Note
Supply Break Down Voltage	V _{cc}	5V Model 12V Model	-0.5 -0.5		+7.0 +15.0	V	
Control Voltage	V _c		-1		9	V	

Environmental and Mechanical

Parameter	Specification
Mechanical Shock	Per MIL-STD-202, 30G, half sine pulse, 11ms
Vibration	Per MIL-STD-202, 5G swept sine 10 to 500Hz
Soldering Conditions	260°C for 10s max
Storage Temperature	-60 to +90°C

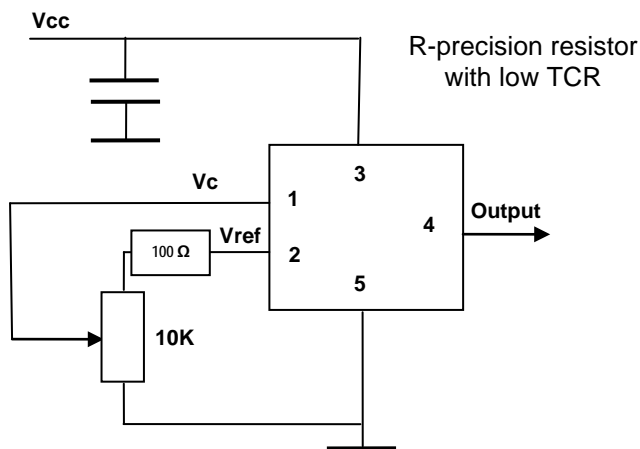

Pin #	Connection
1	V _c
2	V _{ref}
3	V _{cc}
4	Output
5	GND

VFOV302 package

