

**WORK
SATCOM**

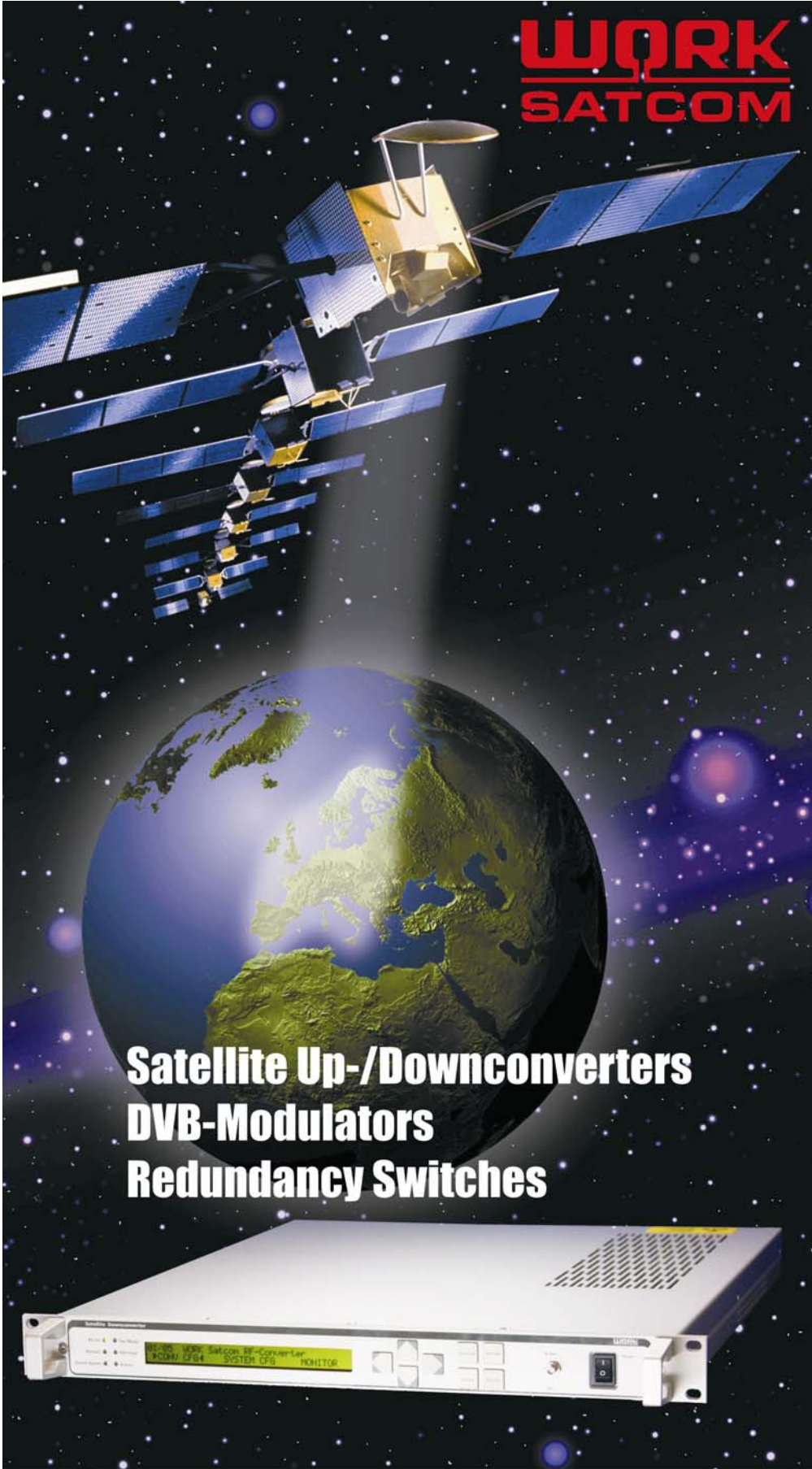

**Satellite Up-/Downconverters
DVB-Modulators
Redundancy Switches**

With kind permission of SES Astra. SES Astra is the worldwide leading satellite organisation and they have been using WORK Satellite Up-/Downconverters for many years.

Work Satcom Part-No. Generator Software Tool

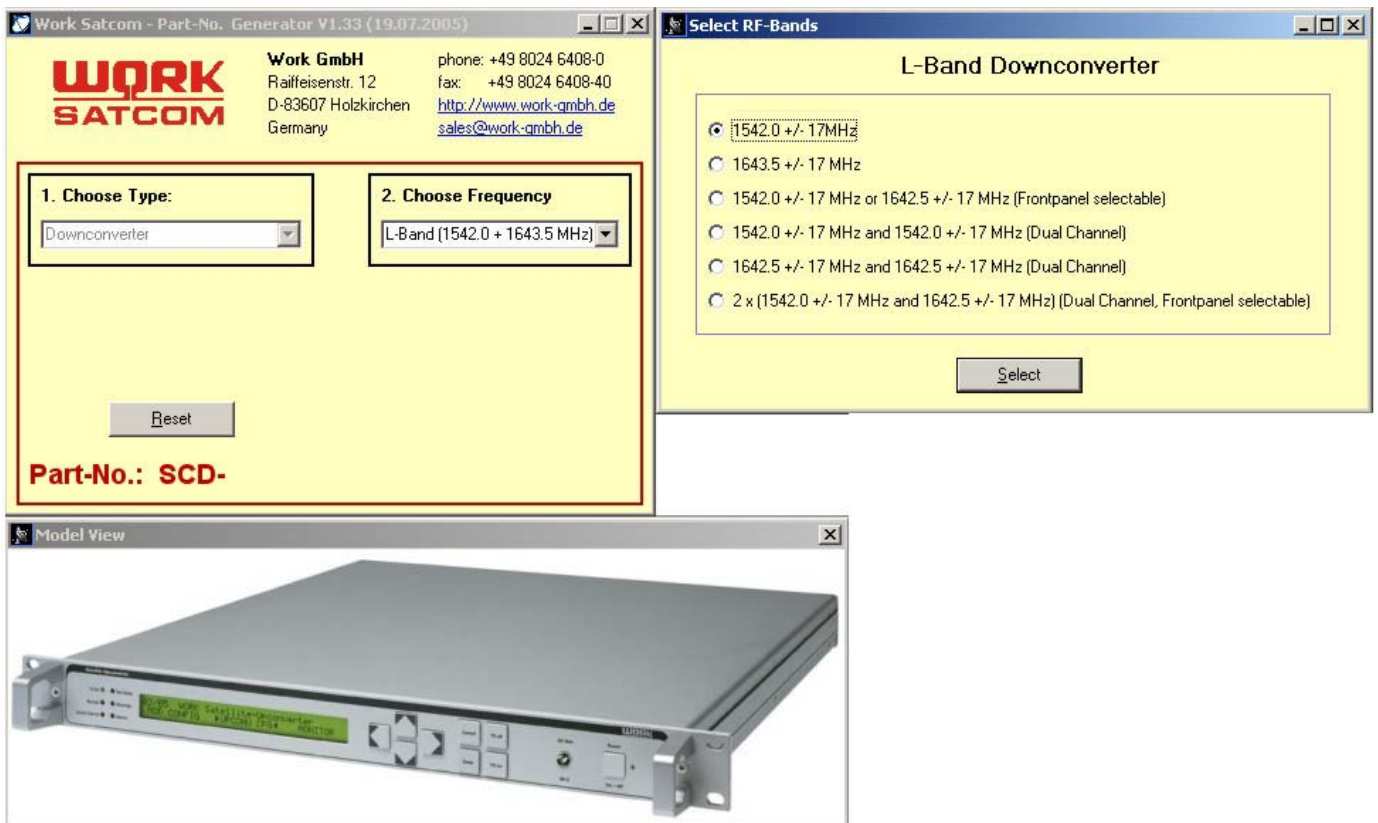

Download Your own free copy !

http://www.work-gmbh.de/work_satcom_pn_generator.zip

or

http://www.work-gmbh.de/work_satcom_pn_generator.exe

WQK SATCOM

Raiffeisenstr. 12
D-83607 Holzkirchen
Germany

phone: +49 (0)8024 6408 - 0
fax: +49 (0)8024 6408 - 40

e-mail: sales@work-gmbh.de

web: www.work-gmbh.de



DIN EN ISO 9001:2000
Zertifikat Nr. 20 100 42000758
www.tuv.at

Single / Dual / Triple Band Satellite Up- and Down- Converters, S-, C-, X-, Ku-, K-, Ka*-Band



Indoor Version



The satellite up- and downconverters developed and manufactured by WORK are designed to meet the requirements of modern satellite transmission, like TV uplink and high speed data networks; analogue transmission formats are as well supported as digital transmission formats. For many years these devices have been used worldwide in fixed satellite earth stations as well as in satellite news gathering (SNG) vehicles and Fly-Aways and other mobile or portable applications (we offer special housings for compact mobile applications). These kind of converters have been built for more than 1200 times so far. Customers worldwide appreciate their reliability and high level of quality. Based on this experience, we are glad to introduce the 4th generation.

NEW 4TH GENERATION – EVEN BETTER

The synthesizer and oscillator segment in any satellite converter is the most important component for reliability. For many years WORK has been developing and building high sophisticated microwave oscillators and synthesizers which are also used in our converter series. The new design allowed us to reduce the number of components by more than 30%. In addition significant circuit improvements were made.

This design results in an AC power consumption of typically 35 VA / 27 W. This leads to an even higher reliability and longer life time.

S-, C-, X-, Ku- AND K-BAND COVERAGE

The satellite converter series cover the satellite frequency bands S-, C-, X-, Ku- and K-Band, a Ka-Band (28 GHz) version is under development. The converters support the standard IF-frequency bands 70 ± 20 MHz and/or 140 ± 40 MHz. The conversion is performed without spectral inversion. The upconverters offer an increased power output ($P_{1dB} \geq +10$ dBm) in all versions. The units are available as single band or as triple band converters (see also next page under “SPECIALS AND OEM PRODUCTS”).

HIGH SIGNAL INTEGRITY

The extreme low phase noise of the oscillators guarantees a very good signal quality. Low spurious emissions allow to use the converters also in environments with demanding requirements, like high power video uplinks. Sophisticated temperature compensation guarantees gain stability over a very wide temperature range.

*for Ka-Band please contact factory

OPERATING AND CONTROL - EASY INTEGRATION INTO YOUR SYSTEM

The converters can be operated via the push buttons on the front panel using self-explanatory display menus or via remote control (RS 232, RS422/485, TCP/IP over Ethernet).

Detailed monitoring of the system status and a summary alarm output (dual change over switch contacts) are provided. For the remote control either ASCII string based commands as well as addressable, packet based commands are provided. Due to the industry standard interfaces, units from other manufacturers can quite easily be replaced.

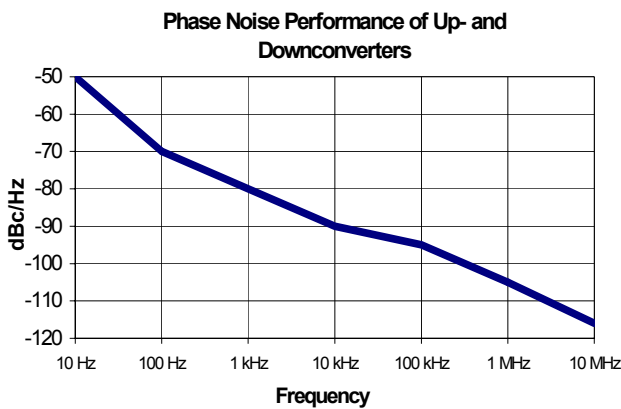

SPECIALS AND OEM PRODUCTS

WORK is specialized to offer custom tailored products. More than 40% of our converters are sold as OEM products with our customer's brand name and logo on it.

We offer specials as follows:

- Modified or smaller housings to fit into your existing design for mobile and portable applications.
- Different front panels with 10 digit keypad.
- Dual- or Quad-Band or other Tri-Band versions.
- Different IF or RF frequency bands, Ka-Band (28GHz) version is under development.
- Customized M&C interface and control syntax.
- Switchable IF 70 and 140 MHz available.
- Extended storage or operating temperature range.
- Military versions for hostile environment (shock, vibration, humidity).

KEY FEATURES

- 70 MHz or 140 MHz IF bands available
- Extreme low power consumption maximum 35 VA / 27 W (single band unit) 37 VA / 29 W (triple band units)
- Extreme low phase noise (< -50 dBc/Hz @ 10 Hz)
- Long- term stability 10^{-7} / year
- Output power +10 dBm (1dB compression point)
- Low spurious emissions < - 80 dBm at full gain (high performance series)
- Automatic reference recognition (5 and 10 MHz)
- Adjustable equalizer ± 2.5 dB / 40 MHz
- Digital gain compensation
- Operating temperature range either -30°C to 60°C (-22°F to 140°F) or 0°C to 50°C (32°F to 122°F)
- Remote control (RS232 and RS422/485 interfaces), TCP/IP over Ethernet
- Packet command syntax supports 2-wire or 4-wire bus systems and allows addressed operation
- RF test output on the front panel
- On/standby switch on the front panel
- Summary alarm output (dual change over switch contacts)
- Transmit mute input
- CE compliant
- **3 years warranty**

ORDER INFORMATION

WORK offers two series of 19" rack satellite converters, Standard and High Performance. The specifications are the same for both types except the operating temperature range. The High Performance type operates between -30°C to 60°C (-22°F to 140°F) and the standard type between 0°C to 50°C (32°F to 122°F). So if you only need units for inside use, the standard unit is perfectly suited for this application and it is significant cheaper.

OPEN QUESTIONS, DEMO UNITS

If you need more information about WORK's new 4th satellite converter generation or if you would like to have demo unit, please contact us via e-mail: sales@work-gmbh.de or call us. We are glad to assist you.

Upconverters High Performance Type (H..) and Standard Type (S..), Indoor Version Parameters depending on RF Frequency Bands

Triband Upconverter Type:	HCU-CXKu, HCU-CKuK			
Dualband Upconverter Type:	Please contact factory			
Singleband Upconverter Type:	HCU-C / SCU-C	HCU-X	HCU-Ku / SCU-Ku	HCU-Ka** / SCU-Ka**
RF-Output Frequency:	C-Band 5.85...6.65 GHz	X-Band 7.90...8.40 GHz	Ku-Band 12.75...14.50 GHz	Ka-Band 29.7...31.5 GHz
Intermediate Frequency:	2450 MHz for 70 MHz IF Input 2440 MHz for 140 MHz IF Input	2450 MHz for 70 MHz IF Input 2440 MHz for 140 MHz IF Input	2450 MHz for 70 MHz IF Input 2440 MHz for 140 MHz IF Input	2450 MHz for 70 MHz IF Input 2440 MHz for 140 MHz IF Input
Phase Noise:	10 Hz -55 -69 ²⁾ 100 Hz -75 -79 ²⁾ 1 kHz -85 -89 ²⁾ 10 kHz -95 -99 ²⁾ 100 kHz -100 ¹⁾ -101 ²⁾¹⁾ 1 MHz -110 ¹⁾ -114 ²⁾¹⁾	-53 -67 ²⁾ -73 -77 ²⁾ -83 -87 ²⁾ -93 -97 ²⁾ -98 ¹⁾ -99 ²⁾¹⁾ -108 ¹⁾ -112 ²⁾¹⁾	-50 -64 ²⁾ -70 -74 ²⁾ -80 -84 ²⁾ -90 -94 ²⁾ -95 ¹⁾ -96 ²⁾¹⁾ -105 ¹⁾ -109 ²⁾¹⁾	-56 -66 -76 -86 -88 ¹⁾ -101 ¹⁾
	max. values in dBc/ Hz ¹⁾ 0°C to 50°C, outside this temperature range degraded by max 5 dB. ²⁾ with option: low phase noise			
Test Output: (Fixed Oscillator)	2520 MHz (70 MHz IF) 2580 MHz (140 MHz IF) -6 ± 3 dBm SMA female	2520 MHz (70 MHz IF) 2580 MHz (140 MHz IF) -6 ± 3 dBm SMA female	2520 MHz (70 MHz IF) 2580 MHz (140 MHz IF) -6 ± 3 dBm SMA female	2380 MHz (70 MHz IF) 2310 MHz (140MHzIF) -6 ± 3 dBm SMA female
Test Output: (Microwave Oscillator)	8.30...9.10 GHz (70 MHz IF) 8.29...9.09 GHz (140 MHz IF) -7 ± 3 dBm SMA female	10.35...10.85 GHz (70 MHz IF) 10.34...10.84 GHz (140 MHz IF) -7 ± 3 dBm SMA female	15.20...16.95 GHz (70 MHz IF) 15.19...16.94 GHz (140 MHz IF) -7 ± 3 dBm SMA female	27.25...29.05 GHz (70 MHz IF) 27.26...29.06 GHz (140 MHz IF) -10 ± 3 dBm SMA female

** for Ka-Band please contact factory

Upconverters High Performance Type (H..) and Standard Type (S..), Indoor Version Parameters depending on RF Frequency Bands

Singleband Upconverter Type:	HCU-S / SCU-S	HCU-K / SCU-K
RF-Output Frequency:	S-Band 2.025...2.110 GHz	K-Band 17.3...18.4 GHz
Intermediate Frequency:	2450 MHz for 70 MHz IF Input 2440 MHz for 140 MHz IF Input	2450 MHz for 70 MHz IF Input 2440 MHz for 140 MHz IF Input
Phase Noise:	10 Hz -60 100 Hz -80 1 kHz -90 10 kHz -100 100 kHz -105 ¹⁾ 1 MHz -112 ¹⁾	-50 -64 ²⁾ -70 -74 ²⁾ -80 -84 ²⁾ -90 -94 ²⁾ -95 ¹⁾ -96 ²⁾¹⁾ -105 ¹⁾ -109 ²⁾¹⁾
	max. values in dBc/ Hz ¹⁾ 0°C to 50°C, outside this temperature range degraded by max 5 dB. ²⁾ with option: low phase noise	
Test Output: (Fixed Oscillator)	2520 MHz (70 MHz IF) 2580 MHz (140 MHz IF) -6 ± 3 dBm SMA female	2380 MHz (70 MHz IF) 2300 MHz (140MHzIF) -6 ± 3 dBm SMA female
Test Output: (Microwave Oscillator)	4.475...4.560 GHz (70 MHz IF) 4.465...4.540 GHz (140 MHz IF) -7 ± 3 dBm SMA female	14.85...15.95 GHz (70 MHz IF) 15.86...15.96 GHz (140 MHz IF) -7 ± 3 dBm SMA female

Specifications are subject to change

**S-Band: 2.025 – 2.290 GHz on request

Other frequency bands on request

Upconverters High Performance Type (H..) and Standard Type (S..), Indoor Version Common Parameters

Conversion Scheme:	Dual up-conversion, no frequency inversion (optional: frequency inversion or switchable)	
Frequency Resolution:	10 Hz	
IF-Input Characteristics:	Frequency: Impedance: Return Loss: IF-Connectors:	70 ± 20 MHz or 140 ± 40 MHz (optional: both → [IF-Band] = 70/140) 50 or 75 Ω 26 dB min BNC female
RF-Output Characteristics:	Impedance: Return Loss: ¹⁾ 1 dB Compression Point: Output Muting: RF-Signal Monitor: RF-Connectors:	50 Ω >20 dB >10 dBm >60 dB (by command or sense input or by alarm condition) -20 dB of RF-output SMA female
Transfer Characteristics:	Max. Conversion Gain: Attenuation Range: Gain Accuracy: Level Stability: Amplitude Response: Image Rejection: Noise Figure:	40 dB 0...30 dB, Step 0.1 dB (Conversion Gain 40...10 dB) ± 1 dB ± 0.25 dB/day (constant temperature) ± 0.25 dB / ±20 MHz, ±0.2 dB / ± 18 MHz >80 dB <25 dB, 20 dB typical
Equalizer (Gain Slope):	± 2.5 dB / 40 MHz (programmable)	
Group Delay (± 18 MHz):	Linear: Parabolic: Ripple:	0.03 ns / MHz max. 0.01 ns / MHz ² max. 1 ns peak to peak max.
Group Delay (± 36 MHz):	Linear: Parabolic: Ripple:	0.015 ns / MHz max. 0.005 ns / MHz ² max. 0.5 ns peak to peak max.
Intermodulation (3rd Order):	36 dBc min (f _{in} : 67.5 and 72.5 MHz, P _{in} : 2 x -25 dBm, P _{out} : 2 x 0 dBm)	
AM / PM conversion:	0.1° / dB (P _{out} = 0 dBm)	
Spurious Outputs:	Signal related: Signal independent:	< - 60 dBc (Δf < 1 MHz), < -70 dBc (Δf ≥ 1 MHz) < - 70 dBm
Frequency Stability:	± 1 x 10 ⁻⁷ , 0°C to 50°C ± 2 x 10 ⁻⁸ , 0°C to 50°C (after 30 min warm up) ± 5 x 10 ⁻⁹ per day (fixed temperature after 24 h warm up)	
Reference Input:	Frequency: Level: Modes: Connector:	10 MHz or 5 MHz -3...10 dBm internal, external, auto (senses reference input) BNC female
Reference Output:	Frequency: Level: Connector:	10 MHz 0 ± 3 dBm BNC female
Monitoring and Control Interface:	TCP/IP over Ethernet (10 or 100 Mbit/s, auto sensing) RS232 or RS422/RS485 (Connectors DSUB09 female) (configurable by software) Mute Input: TTL logic input with internal pull up	
Alarm Interface:	Two potential free contacts (DPDT, Connector DSUB09 female)	
Temperature Range:	HCU: -30°C to 60°C operating (10 minutes warm up at -30°C) SCU: 0°C to 50°C operating - 30°C to 80°C storage	
Relative Humidity:	< 95 % non condensing	
User Interface:	SCU: LCD-Display 2 x 40 characters, 4 cursor keys, 4 function keys HCU: VFD-Display 2 x 40 characters, 4 cursor keys, 4 function keys	
Power Supply:	85...264 V AC, 40...70 Hz	
Power Consumption:	Max: 33 VA / 20 W Typ: 29 VA / 18 W	
Mains Fuse:	2 x 3.15 A time-lag fuse	
Dimension and Weight:	483 x 44 x 500 mm ³ , 1 RU (19") appr. 8.4 kg	

Specifications are subject to change

1) HCU-CKuK: Output Return Loss = 17 dB

Order Information:	HCU-[RF Band]-[IF Band]-[IF Imp] or SCU-[RF Band]-[IF Band]-[IF Imp] Example: HCU-C-70-50 or SCU-Ku-140-75
---------------------------	---

Downconverter High Performance Type (H..) and Standard Type (S..), Indoor Version Parameters depending on RF Frequency Bands

Triband Downconverter Type:	HCD-CXKu			
Dual Band Downconverter Type:	Please contact factory			
Singleband Downconverter Type:	HCD-S / SCD-S	HCD-C / SCD-C	HCD-X	HCD-Ku / SCD-Ku
RF-Input Frequency:	S-Band 2.2...2.3 GHz**	C-Band 3.4...4.2 GHz	X-Band 7.25...7.75 GHz	Ku-Band 10.70...12.75 GHz
Intermediate Frequency:	2450 MHz for 70 MHz IF Output 2440 MHz for 140 MHz IF Output	2150 MHz for 70 MHz IF Output 2140 MHz for 140 MHz IF Output	2150 MHz for 70 MHz IF Output 2140 MHz for 140 MHz IF Output	2150 MHz for 70 MHz IF Output 2140 MHz for 140 MHz IF Output
Phase Noise:	10 Hz 100 Hz 1 kHz 10 kHz 100 kHz 1 MHz	-60 -80 -90 -96 -105 ¹⁾ -112 ¹⁾	-56 -71 ²⁾ -76 -81 ²⁾ -86 -91 ²⁾ -96 -101 ²⁾ -101 ¹⁾ -103 ²⁾¹⁾ -111 ¹⁾ -116 ²⁾¹⁾	-53 -68 ²⁾ -73 -78 ²⁾ -83 -88 ²⁾ -93 -98 ²⁾ -98 ¹⁾ -100 ²⁾¹⁾ -108 ¹⁾ -113 ²⁾¹⁾
	max. values in dBc/ Hz ¹⁾ 0°C to 50°C, outside this temperature range degraded by max 5 dB. ²⁾ with option: low phase noise			
Test Output (Fixed Oscillator):	2520 MHz (70 MHz IF) 2580 MHz (140 MHz IF) -6 ± 3 dBm, Connector SMA female	2220 MHz (70 MHz IF) 2280 MHz (140 MHz IF) -6 ± 3 dBm, Connector SMA female	2220 MHz (70 MHz IF) 2280 MHz (140 MHz IF) -6 ± 3 dBm, Connector SMA female	2220 MHz (70 MHz IF) 2280 MHz (140 MHz IF) -6 ± 3 dBm, Connector SMA female
Test Output (Microwave Oscillator):	4.65...4.75 GHz (70 MHz IF) 4.64...4.74 GHz (140 MHz IF) -7 ± 3 dBm SMA female	5.55...6.35 GHz (70 MHz IF) 5.54...6.34 GHz (140 MHz IF) -7 ± 3 dBm SMA female	9.40...9.90 GHz (70 MHz IF) 9.39...9.89 GHz (140 MHz IF) -7 ± 3 dBm SMA female	12.85...14.90 GHz (70 MHz IF) 12.84...14.89 GHz (140 MHz IF) -7 ± 3 dBm SMA female

Specifications are subject to change

**S-Band: 2.025 – 2.290 GHz on request

Other frequency bands on request

Downconverter High Performance Type (H..) and Standard Type (S..), Indoor Version Common Parameters

Conversion Scheme:	Dual down-conversion, no frequency inversion (optional: frequency inversion or switchable)		
Frequency Resolution:	10 Hz		
RF-Input Characteristics:	Impedance: Return Loss: Max. input level: LO Leakage: RF-Connector:	50 Ω >20 dB < approx. -25 dBm (operational) < approx. +10 dBm (damage level) -80 dBm max. SMA female	
IF-Output Characteristics:	Frequency: Impedance: Return Loss: 1 dB Compression Point: Output Muting: IF-Signal Monitor: IF-Connectors:	70 ± 20 MHz or 140 ± 40 MHz (optional: both → [IF-Band] = 70/140) 50 or 75 Ω 26 dB min >10 dBm, 13 dBm typical >60 dB (by command or sense input or by alarm condition) -20 dB of IF-output BNC female	
Transfer Characteristics:	Max. Conversion Gain: Attenuation Range: Gain Accuracy: Level Stability: Amplitude Response: Image Rejection: Noise Figure:	45 dB 0...30 dB, Step 0.1 dB (Conversion Gain 45...15 dB) ± 1 dB ± 0.25 dB/day (constant temperature) ± 0.25 dB / ±20 MHz, ±0.2 dB / ± 18 MHz >80 dB <12 dB, 10 dB typical	
Equalizer (Gain Slope):	± 2.5 dB / 40 MHz (programmable)		
Group Delay (± 18 MHz):	Linear: Parabolic: Ripple:	0.03 ns / MHz max. 0.01 ns / MHz ² max. 1 ns peak to peak max.	
Group Delay (± 36 MHz):	Linear: Parabolic: Ripple:	0.015 ns / MHz max. 0.005 ns / MHz ² max. 2 ns peak to peak max.	
Intermodulation (3rd Order):	60 dBc min (Δf _{in} : 5 MHz, P _{in} : 2 x -40 dBm, P _{out} : 2 x -10 dBm)		
AM / PM conversion:	0.1° / dB (P _{out} = 0 dBm)		
Spurious Outputs:	Signal related: Signal independent:	< -60 dBc (Δf < 1 MHz), < -70 dBc (Δf ≥ 1 MHz) < -76 dBm (< -80 dBm typical)	
Frequency Stability:	± 1 x 10 ⁻⁷ 0°C to 50°C ± 2 x 10 ⁻⁸ , 0°C to 50°C (after 30 min warm up) ± 5 x 10 ⁻⁹ per day (fixed temperature after 24 h warm up)		
Reference Input:	Frequency: Level: Modes: Connector:	10 MHz or 5 MHz -3...10 dBm internal, external, auto (senses reference input) BNC female	
Reference Output	Frequency: Level: Connector:	10 MHz 0 ± 3 dBm BNC female	
Monitoring and Control Interface:	TCP/IP over Ethernet (10 or 100 Mbit/s, auto sensing) RS232 or RS422/RS485 (Connectors DSUB09 female) (configurable by software) Mute Input: TTL logic input with internal pull up		
Alarm Interface:	Two potential free contacts (DPDT, Connector DSUB09 female)		

Temperature Range:	HCU : -30°C to 60°C operating (10 minutes warm up at -30°C) SCU : 0°C to 50°C operating - 30°C to 80°C storage
Relative Humidity:	< 95 % non condensing
User Interface:	SCU: LCD-Display 2 x 40 characters, 4 cursor keys, 4 function keys HCU: VFD-Display 2 x 40 characters, 4 cursor keys, 4 function keys
Power Supply:	85...264 V AC, 40...70 Hz
Power Consumption:	Max: 33 VA / 20 W Typ: 29 VA / 18 W
Mains Fuse:	2 x 3.15 A time-lag fuse
Dimension and Weight:	483 x 44 x 500 mm ³ , 1 RU (19") appr. 8.2 kg

Specifications are subject to change

Order Information:	HCD-[RF Band]-[IF Band]-[IF Imp] or SCD-[RF Band]-[IF Band]-[IF Imp] Example: HCD-C-140-50 or SCD-Ku-70-75
---------------------------	---

Single Band Synthesized Block Downconverter Specification Ku-Band Input, L-Band Output, High Performance Type (H..) and Standard Type (S..), Indoor Version			
Downconverter Type:	HSBD-Ku / SSBD-Ku		
RF-Input Frequency:	10.70...12.75 GHz ¹⁾		
Conversion Scheme:	Single down-conversion, no frequency inversion		
LO Frequency:	9.75...11.3 GHz, Resolution 10 Hz		
RF-Input Characteristics:	Impedance: Return Loss: Maximum Aggregate Input Level: LO Leakage: RF-Connector:	50 Ω > 20 dB < approx. -25 dBm (operational) < approx. +10 dBm (damage level) -80 dBm max. SMA female	
IF-Output Characteristics:	Frequency: Impedance: Return Loss: 1 dB Compression Point: Output Muting: IF-Connectors:	950...1500 MHz 50 Ω or 75 Ω > 20 dB > 17 dBm > 70 dB (by command or sense input or by alarm condition) SMA female	
Transfer Characteristics:	Conversion Gain: Gain Accuracy: Level Stability: Amplitude Ripple: Image Rejection: Noise Figure:	40 dB ± 1.5 dB ± 0.25 dB/day (constant temperature) ± 0.25 dB / 20 MHz > 80 dB < 11 dB	
Group Delay (950...1500 MHz):	Flat, Ripple:	1 ns peak to peak max.	
Intermodulation (3rd Order):	< -50 dBc (Δf_{in} : 5 MHz, $P_{out\ ges}$: < +8 dBm) OIP3: +30 dBm		
AM / PM conversion:	0.1° / dB (P_{out} = 0 dBm)		
Phase Noise:	10 Hz 100 Hz 1 kHz 10 kHz 100 kHz 1 MHz	- 50 dBc/Hz - 70 dBc/Hz - 80 dBc/Hz - 90 dBc/Hz - 95 dBc/Hz ¹⁾ -105 dBc/Hz ¹⁾	¹⁾ 0°C to 50°C, outside this temperature range degraded by max 5 dB.
Spurious Outputs:	Signal independent:	< - 70 dBc < - 55 dBc (< 100 kHz offset) < - 80 dBm	
Frequency Stability:	± 1 x 10 ⁻⁷ , 0°C to 50°C. ± 2 x 10 ⁻⁸ , 0°C to 50°C (after 10 min warm up) ± 5 x 10 ⁻⁹ per day (fixed temperature after 24 h warm up)		
Reference Input:	Frequency: Level: Modes: Impedance: Connector:	10 MHz or 5 MHz -3...10 dBm internal, external, auto (senses reference input) 50 Ω BNC female	
Reference Output:	Frequency: Level: Impedance: Connector:	10 MHz 0 ± 3 dBm 50 Ω BNC female	
Test Output: (Microwave Oscillator)	Frequency: Level: Impedance: Connector:	9.75...11.3 GHz -7 ± 3 dBm 50 Ω SMA female	
Monitoring and Control Interface:	TCP/IP over Ethernet (10 or 100 Mbit/s, auto sensing) RS232 or RS422/RS485 (Connectors DSUB09 female) (configurable by software) Mute Input: TTL logic input with internal pull up		
Alarm Interface:	Two potential free contacts (DPDT, Connector DSUB09 female)		
Temperature Range:	HSBD: -30°C to 60°C operating (10 minutes warm up at -30°C) SSBD: 0°C to 50°C operating - 30°C to 80°C storage		
Relative Humidity:	< 95 % non condensing		
User Interface:	SSBD: LCD-Display 2 x 40 characters, 4 cursor keys, 4 function keys HSBD: VFD-Display 2 x 40 characters, 4 cursor keys, 4 function keys		
Power Supply:	85...264 V AC, 40...70 Hz		
Power Consumption:	Max: 33 VA / 20 W Typ: 29 VA / 18 W		
Mains Fuse:	2 x 3.15 A time-lag fuse		
Dimension and Weight:	483 x 44 x 500 mm ³ , 1 RU (19") appr. 8.2 kg		
Order Information:	HSBD-[Input Band]¹⁾ or SSBD-[Input Band]¹⁾ Example: SSBD-Ku		

Specifications are subject to change ¹⁾Other frequency bands on request

Single Band Block Downconverter Specification C-Band Input, L-Band Output, Standard Type, Indoor Version			
Downconverter Type:	BD-C		
RF-Input Frequency:	3.50...3.70 GHz		
Conversion Scheme:	Single down-conversion, frequency inversion		
LO Frequency:	5.154 GHz		
RF-Input Characteristics:	Impedance: Return Loss: Maximum Aggregate Input Level: LO Leakage: RF-Connector:	50 Ω >20 dB (VSWR = 1.22) - 17 dBm -80 dBm max. SMA female	
IF-Output Characteristics:	Frequency: Impedance: Return Loss: 1 dB Compression Point: IF-Connectors:	1454...1654 MHz 50 Ω >15 dB (VSWR = 1.43) >19 dBm SMA female	
Transfer Characteristics:	Conversion Gain: Level Stability: Amplitude Ripple: Image Rejection: Noise Figure:	35 +/-2 dB (within the operating temperature range) ± 0.25 dB/day (constant temperature) ± 0.2 dB / 20 MHz >80 dB <11 dB	
Group Delay (1454...1654 MHz):	Flat, Ripple:	1 ns peak to peak max.	
Intermodulation (3rd Order):	< -60 dBc (Δf_{in} : 5 MHz, $P_{out\ ges}$: < 3 dBm)		
AM / PM conversion:	0.1° / dB (P_{out} = 0 dBm)		
Phase Noise:	10 Hz 100 Hz 1 kHz 10 kHz 100 kHz 1 MHz	- 62 dBc/Hz - 83 dBc/Hz - 89 dBc/Hz - 101 dBc/Hz - 104 dBc/Hz ¹⁾ - 111 dBc/Hz ¹⁾	¹⁾ 0°C to 50°C, outside this temperature range degraded by max 5 dB.
Spurious Outputs:	Signal independent:	< - 70 dBc < - 80 dBm	
Frequency Stability:	± 1 x 10 ⁻⁷ , 0°C to 50°C. ± 2 x 10 ⁻⁸ , 0°C to 50°C (after 10 min warm up) ± 5 x 10 ⁻⁹ per day (fixed temperature after 24 h warm up)		
Reference Input:	Frequency: Level: Modes: Connector:	10 MHz or 5 MHz -5...10 dBm auto (senses reference input) BNC female	
Reference Output:	Frequency: Level: Connector:	10 MHz 0 ± 3 dBm BNC female	
Test Output (Microwave Oscillator):	5.154 GHz -7 ± 3 dBm SMA female		
Temperature Range:	0°C to 50°C operating - 30°C to 80°C storage		
Relative Humidity:	< 95 % non condensing		
Power Supply:	85...264 V AC, 40...70 Hz		
Power Consumption:	Max: 19 VA / 13 W Typ: 16 VA / 10 W		
Mains Fuse:	1.6 A time-lag fuse		
Dimension and Weight:	483 x 44 x 323 mm ³ , 1 RU (19") (maximum dimension) 436 x 44 x 280 mm ³ (dimension without frontpanel) appr. 3 kg		

Order Information:	BD-C-C0001
---------------------------	-------------------

Specifications are subject to change

Single-Band Downconverter Specification S-Band Input, L-Band Output, Standard Type (S.), Indoor Version			
Downconverter Type:	SCD-S		
Frequency resolution:	100 kHz		
RF-Input Frequency:	2.3...2.9 GHz		
Conversion Scheme:	Single down-conversion, no frequency inversion		
LO Frequency:	1.55...2.2 GHz		
RF-Input Characteristics:	Impedance: Return Loss: Maximum Aggregate Input Level: LO Leakage RF-Connector	50 Ω > 15 dB (VSWR = 1.22) 0 dBm -42 dBm max. SMA female	
IF-Output Characteristics:	Frequency: Impedance: Return Loss: 1 dB Compression Point: IF-Connectors:	700...750 MHz 50 Ω > 15 dB (VSWR = 1.22) > +7 dBm SMA female	
Transfer Characteristics:	Conversion Gain: Gain-Resolution: Gain Accuracy: Gain Stability: Amplitude Ripple: IF Output Bandwidth (3 dB): Noise Figure:	5...35 dB 1 dB ± 0.2 dB typical (± 0.3 dB max.) ± 0.25 dB/day (constant temperature) ± 0.2 dB / 20 MHz 1 GHz ²⁾ < 12 dB ²⁾	
Group Delay (700...750 MHz):	Flat, Ripple:	1 ns peak to peak max.	
Intermodulation (3rd Order):	< -60 dBc (Δf_{in} : 5 MHz, $P_{out\ ges}$: < -12 Bm) (OIP3 = +15 dBm)		
AM / PM conversion:	0.1° / dB (P_{out} = 0 dBm)		
Phase Noise:	10 Hz 100 Hz 1 kHz 10 kHz 100 kHz 1 MHz	- 50 dBc/Hz - 70 dBc/Hz - 80 dBc/Hz - 83 dBc/Hz - 95 dBc/Hz ¹⁾ - 111 dBc/Hz ¹⁾	¹⁾ 0°C to 50°C, outside this temperature range degraded by max 5 dB.
Spurious Outputs:	Signal dependent:	< - 55 dBc	
Frequency Stability:	± 1 x 10 ⁻⁷ , 0°C to 50°C with OCXO ± 2 x 10 ⁻⁸ , 0°C to 50°C (after 10 min warm up) ± 5 x 10 ⁻⁹ per day (fixed temperature after 24 h warm up)		
Test Output: (Microwave Oscillator)	not available		
Temperature Range:	0°C to 50°C operating - 30°C to 80°C storage		
Relative Humidity:	< 95 % non condensing		
Power Supply:	85...264 V AC, 40...70 Hz		
Power Consumption:	Max: 24 VA / 14 W Typ: 20 VA / 11 W		
User Interface	LCD, 2 x 40 characters, 4 cursor keys, 2 function keys Mains Power Switch on Front Panel		
Mains Fuse:	3.15 A time-lag fuse		
Dimension and Weight:	483 x 44 x 323 mm ³ , 1 RU (19") (maximum Dimension) 436 x 44 x 280 mm ³ (Dimension without Frontpanel) appr. 3.5 kg		

Order Information:	SCD-S-725-[IF Imp]-LC Example: SCD-S-725-50-LC or SCD-S-725-75-LC
---------------------------	--

Specifications are subject to change

²⁾ S/N [dB] = P_{in} [dBm] + 174 [dBm/Hz] - 12 [dB] - 10 log (10⁹ [Hz]) = P_{in} [dBm] + 72 [dB] (approx.)

Single-Band or Dual Channel Downconverter Specification High Performance Type (H..) and Standard Type (S..), Indoor Version			
Downconverter Type:	HCD-L(x) / SCD-L(x) or HCD-L(x)L(x) / SCD-L(x)L(x)		
RF-Input Frequency:	L-Band L1: 1525,0...1559,0 MHz (single band) L2: 1626,5...1660,5 MHz (single band) L: 1525,0...1559,0 MHz or 1626,5...1660,5 MHz (single band, frontpanel selectable) L1L1: 1525,0...1559,0 MHz and 1525,0...1559,0 MHz (dual channel) L2L2: 1626,5...1660,5 MHz and 1626,5...1660,5 MHz (dual channel) LL: 1525,0...1559,0 MHz and 1626,5...1660,5 MHz (dual channel, frontpanel selectable)		
Conversion Scheme:	Single down conversion, no frequency inversion		
LO-Frequency:	L1: 1402,0 MHz L2: 1503,5 MHz		
RF-Input Characteristics:	Impedance: Return Loss: RF-Connector: Max. Input Level: IIP ₃ : Cross Talk:	50 Ω >18 dB SMA female -20 dBm @ IP3 < -60 dBc (operation) -10 dBm @ IP3 < -30 dBc (operation) +10 dBm (damage level) 0 dBm Unit 1 to IF out @ unit 2: < -80 dB (only dual channel)	
IF-Output Characteristics:	Frequency: Impedance: Return Loss: 1 dB Compression Point: Output Muting: IF-Signal Monitor: IF-Connector:	140 ± 17 MHz 50 or 75 Ω > 18 dB >10 dBm, 13 dBm typical >60 dB (by command or sense input or by alarm condition) -12 dB of IF-output SMA female	
Transfer Characteristics:	Max. Conversion Gain: Attenuation Range: Gain Accuracy: Level Stability: Amplitude Response: Noise Figure:	35 dB 0...30 dB, Step 0.1 dB (Conversion Gain 35...5 dB) ± 1 dB ± 0.25 dB/day (constant temperature) ± 0.5 dB / 10 MHz <16 dB	
Equalizer (Gain Slope):	± 2.5 dB / 40 MHz (programmable)		
Intermodulation (3rd Order):	60 dBc min (Δf _{in} : 5 MHz, P _{in} : 2 x -40 dBm, P _{out} : 2 x -10 dBm)		
Phase Noise:	10 Hz 100 Hz 1 kHz 10 kHz 100 kHz 1 MHz	- 55 dBc/Hz - 75 dBc/Hz - 85 dBc/Hz - 95 dBc/Hz - 100 dBc/Hz ¹⁾ - 120 dBc/Hz ¹⁾	¹⁾ 0°C to 50°C, outside this temperature range degraded by max 5 dB.
Spurious Outputs:	Signal related: Signal independent:	< - 60 dBc (Δf < 1 MHz), < -70 dBc (Δf ≥ 1 MHz) < - 76 dBm (< - 80 dBm typical)	
Frequency Stability:	± 1 x 10 ⁻⁷ , 0°C to 50°C ± 2 x 10 ⁻⁸ , 0°C to 50°C (after 30 min warm up) ± 5 x 10 ⁻⁹ per day (fixed temperature after 24 h warm up)		
Reference Input:	Frequency: Level: Modes: Connector:	10 MHz or 5 MHz -5...10 dBm internal, external, auto (senses reference input) SMA female	
Reference Output₁:	Frequency: Impedance: Return Loss: Level: Connector:	10 MHz 50 Ω > 15 dB 0 ± 3 dBm SMA female	
Reference Output₂: Option: -PLO ***other frequencies on request	Frequency: Impedance: Return Loss: Harmonics: Level: Connector:	187.20*** MHz 50 Ω > 15 dB < -40 dBc 5 ± 1 dBm SMA female	
Monitoring and Control Interface:	RS232 or RS422/RS485 (Connectors DSUB09 female) (selectable by customer), TCP/IP over Ethernet, 10/100 Base-T (RJ45 connector) Mute Input: TTL logic input with internal pull up		
Alarm Interface:	Two potential free contacts (DPDT, Connector DSUB09 female)		
Temperature Range:	HCU: -30°C to 60°C operating (10 minutes warm up at -30°C, the LCD display is operational: -20°C to 60°C) SCU: 0°C to 50°C operating - 30°C to 80°C storage		
Relative Humidity:	< 95 % non condensing		

User Interface:	SCU: LCD-Display 2 x 40 characters, 4 cursor keys, 4 function keys HCU: VFD-Display 2 x 40 characters, 4 cursor keys, 4 function keys	
Power Supply:	85...264 V AC, 40...70 Hz 0.9 A max	
DC Power to external LNA: (DC bias tee included at RF input.) Option: -DC	DC Voltage: Current: Switchable: Protection:	15 V max. 0,4 A (each output) ON / OFF Short circuit protection
Dimension and Weight:	483 x 44 x 500 mm ³ , 1 RU (19") appr. 8.6 kg	

Order Information:	HCD-[L-Band]-140-[IFImp] or SCD-[L-Band]-140-[IFImp] Example: HCD-L1-140-50 or SCD-L2L2-140-75 or SCD-LL-140-50-DC
---------------------------	---

Specifications are subject to change

VHF to IF Downconverter Specification Standard Type (S.), Indoor Version			
Downconverter Type:	DNC-V		
VHF-Input Frequency:	80...200 MHz ¹⁾		
Conversion Scheme:	Single down-conversion, no frequency inversion		
LO Frequency:	80...200 MHz, Resolution 10 Hz		
RF-Input Characteristics:	Impedance: Return Loss: Maximum Aggregate Input Level: RF-Connector:	50 Ω > 14 dB approx. -25 dBm (operational) approx. +10 dBm (damage level) BNC female	
IF-Output Characteristics:	Frequency: Impedance: Return Loss: 1 dB Compression Point: Output Muting: IF-Connectors:	0...30 MHz ¹⁾ 50 Ω > 20 dB > 10 dBm > 60 dB (during warm-up or during alarm condition) BNC female	
Transfer Characteristics:	Conversion Gain: Attenuation Range: Gain Accuracy: Level Stability: Amplitude Ripple: Noise Figure:	45 dB 0...30 dB, Step 0.1 dB (Conversion Gain 45...15 dB) ± 1.5 dB ± 0.25 dB/day (constant temperature) ± 0.25 dB / 20 MHz < 20 dB	
Internal Filter*: *) other filter characteristics on request	4 internal filters 80...110 MHz 110...140 MHz 140...170 MHz 170...200 MHz		
External Filter:	via BNC connectors Impedance: 50 Ohms		
Phase Noise:	10 Hz 100 Hz 1 kHz 10 kHz 100 kHz	- 80 dBc/Hz - 100 dBc/Hz - 110 dBc/Hz - 120 dBc/Hz - 125 dBc/Hz ¹⁾	¹⁾ 0°C to 50°C, outside this temperature range degraded by max 5 dB.
Spurious Outputs:	< - 70 dB		
Frequency Stability:	± 1 x 10 ⁻⁷ , 0°C to 50°C ± 2 x 10 ⁻⁸ , 0°C to 50°C (after 10 min warm up) ± 5 x 10 ⁻⁹ per day (fixed temperature after 24 h warm up)		
Reference Input:	Frequency: Level: Modes: Impedance: Connector:	10 MHz or 5 MHz -3...10 dBm internal, external, auto (senses reference input) 50 Ω BNC female	
Reference Output:	Frequency: Level: Impedance: Connector:	10 MHz 0 ± 3 dBm 50 Ω BNC female	
Monitoring and Control Interface:	TCP/IP over Ethernet (10 or 100 Mbit/s, auto sensing) RS232 or RS422/RS485 (Connectors DSUB09 female) (configurable by software) Mute Input: TTL logic input with internal pull up		
Temperature Range:	0°C to 50°C operating - 30°C to 80°C storage		
Relative Humidity:	< 95 % non condensing		
User Interface:	LCD-Display 2 x 40 characters, 4 cursor keys, 2 function keys		
Power Supply:	85...264 V AC, 40...70 Hz		
Power Consumption:	Max: 33 VA / 20 W Typ: 29 VA / 18 W		
Mains Fuse:	2 x 3.15 A time-lag fuse		
Dimension and Weight:	483 x 44 x 260 mm ³ , 1 RU (19") approx. 4.2 kg		
Order Information:	DNC-V-15-50		

Specifications are subject to change ¹⁾ other frequency bands on request

Automatic Level Control (ALC) Filter Amplifier



**Indoor Version
or Add On**



The Downconverter may optionally include an application specific ALC Filter Amplifier. The input of this module can be connected to the IF output of the Downconverter with a short SMA connection on the rear panel.

Below picture shows a block diagram of the application specific ALC Filter Amplifier. The signal is bandpass filtered on the input as well as on the output. Both bandpass filters are identical. Two pictures on the next page show a typical amplitude frequency response.

In between these filters a variable gain stage allows adjustment of the signal level. A small portion of the output signal level is sent to an RMS detector. A digitally implemented control algorithm using a microprocessor allows to select a specified output level and keeps the output level constant, even if the input signal varies within the allowed level range. The parameters of the ALC amplifier can be configured from the frontpanel processor as well as from remote. Also monitoring of the ALC amplifier is possible from the front panel processor as well as from remote. Besides the main ALC output an ALC Monitor Output is available on the rear panel.

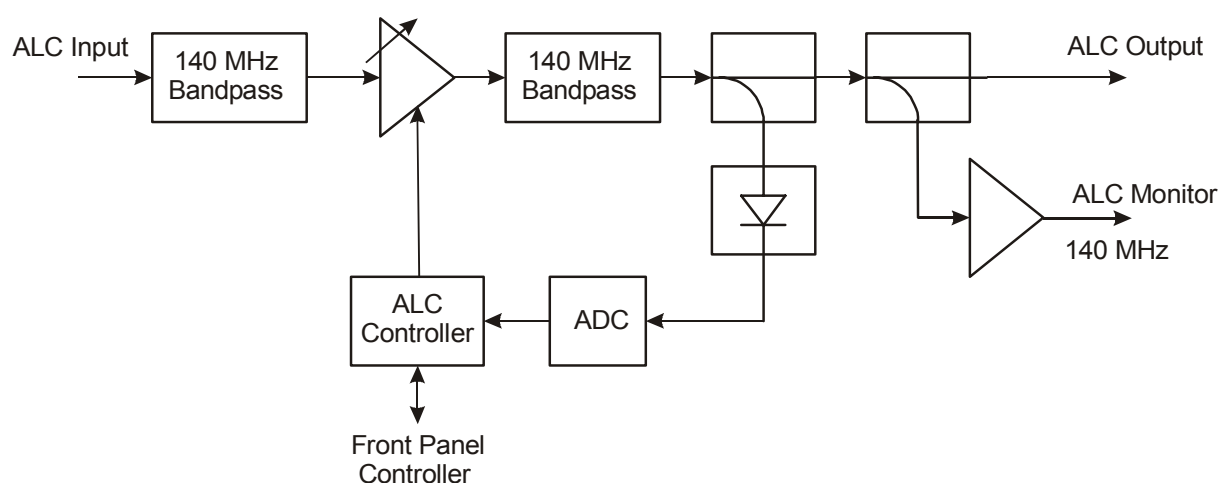

Typical Amplitude-Frequency Response of one 140 MHz Bandpass Filter with 54 MHz Bandwidth (1.5 dB).

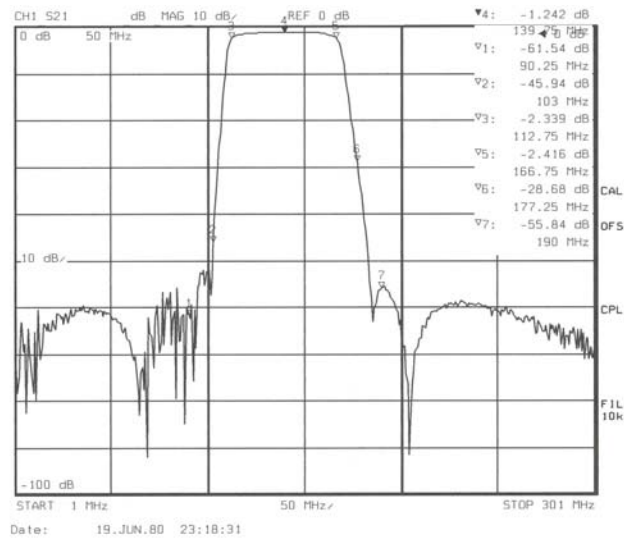

Typical Amplitude-Frequency Response of one 140 MHz Bandpass Filter with 34 MHz Bandwidth (2 dB).

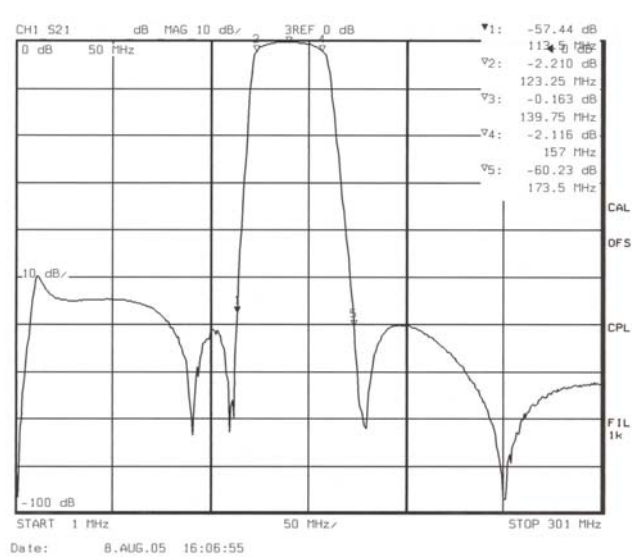

ALC Filter-Amplifier, Indoor Version or Add On-Version

IF Input:	Center Frequency: Frequency Range: Signal Level: Return Loss: Connector: Impedance:	140 MHz 80...200 MHz -50...-20 dBm > 18 dB (within filter passband bandwidth) SMA female 50 Ω
IF Output:	Center Frequency: Bandwidth: Signal Level: Return Loss: Connector: Impedance:	140 MHz 34 MHz or 54 MHz or 75 MHz (→ xxMHz) - 5 dBm.. +10 dBm (adjustable, 0.1 dB step size) > 18 dB (within filter passband bandwidth) SMA female 50 Ω
IF Monitor Output:	Signal similar to IF Output Signal Level: Return Loss: Connector: Impedance:	20 dB lower than IF Output > 20 dB SMA female 50 Ω
Transfer Characteristics:	Gain: Group delay: Bandwidth: Frequency Range:	15...60 dB (automatically or manual adjustable, 0.1 dB step size) < 0.5 ns / 25 kHz within 54 MHz bandwidth 54 MHz (3 dB) 113...167 MHz (3 dB)
Intermodulation (3rd Order):	< -60 dBc, (Pout: 2 x +4 dBm)	
ALC Control:	Fast attack for required gain adjustment > configurable value (0.1...5 dB) with configurable time constant up to 1000 s. Gradual adjustment for required gain adjustment < configurable value (0.1...5 dB) with configurable time constant up to 1000 s Control cycle approx. 100 ms. No interruption of the signal during adjustment.	
Monitoring and Control Interfaces:	Ethernet/IP (10 or 100 Mbit/s, auto sensing) RS232 or RS422/RS485 (Connectors DSUB09 female) (configurable)	
Alarm Interface (Stand Alone):	Two potential free contacts (DPDT, Connector DSUB09 female)	
Temperature Range:	-25°C to 60°C operating the LCD display is operational: -20°C to 60°C - 30°C to 80°C storage	
Relative Humidity:	< 95 % non condensing	
User Interface (Stand Alone):	LCD, 2 x 40 characters, 4 cursor keys, 4 function keys	
Power Supply:	85...264 V AC, 40...70 Hz	
Power Consumption:	max 16 VA / 8 W, typ. 12 VA / 5 W	
Mains Fuse:	3.15 A time-lag fuse	
Dimension and Weight (Stand Alone):	483 x 44 x 270 mm ³ , 1 RU (19") appr. 3.2 kg	

Order Information:

**ALC-5/+10dBm-ID([Bandwidth]) (Stand Alone Unit)
HCD-[RF Band]-140-[IF Imp]-ALC (Example: HCD-C-140-50-ALC)**

Specifications are subject to change

Single / Dual / Triple Band Satellite Up- and Down- Converters S-, C-, X-, Ku-, K-Band



Outdoor Version



For outdoor use under all weather conditions WORK developed a new generation of outdoor satellite up- and downconverters. They operate over a temperature range -30°C to 60°C (-22°F to 140°F). In the non-operating modus they survive temperatures of -50°C to 80°C (-58°F to 176°F) without any damage. Like the 19" rack converters, they meet the requirements for modern satellite transmission like TV up-link and high-speed data network. Due to their rugged construction and low power consumption, they are best fit to be used in fixed satellite earth stations as well as satellite sews gathering (SNG) vehicles, Fly-Aways and other mobile applications (we offer special housings for compact mobile applications, see next page "SPECIALS AND OEM PRODUCTS").

TECHNOLOGY OF THE 4TH GENERATION

All WORK outdoor converters are equipped with the most modern technology of WORK's 4th generation satellite converters. The new design allowed us to reduce the number of components by more than 30%. In addition significant circuit improvements were made. This design results in an AC power consumption of typically 35 VA / 27 W. This leads to an even higher reliability and longer life time.

OUTDOOR INSTALLATION

WORK outdoor converters are best fit to be mounted directly to the antenna. They do not require additional protection against water and rain. The housing provides environmental protection according to IP67 (temporary flooding) when all cables are connected and sealed appropriately. Special environmental protection sleeves for the coaxial connectors allow optimal sealing from the housing to the cable. The housing should be mounted with the connector side down. Alternatively the connector panel can be in a vertical position.

S-, C-, X-, Ku- AND K-, SINGLE, DUAL OR TRIPLE BAND

WORK is offering the satellite outdoor converters as single band units covering S-, C-, X-, Ku-, K-Band (a Ka-Band (28GHz) version is under development) or as Triple band units covering C-, Ku- und K-Band. They support the standard IF-frequency of 70 ± 20 MHz or/and 140 ± 40 MHz. The conversion is performed without spectral inversion. All WORK upconverters offer an increased power output ($P_{1\text{dB}} = +10$ dBm) in all versions.

HIGH SIGNAL INTEGRITY

The extreme low phase noise of the oscillators guarantees a very good signal quality. Low spurious emissions allow using the converters also in environments with demanding requirements, like high power video uplinks. Sophisticated temperature compensation guarantees gain stability over full temperature range.

OPERATING AND CONTROL - EASY INTEGRATION INTO YOUR SYSTEM

The converters can be operated via remote control (RS 232, RS422/485).

Detailed monitoring of the system status and a summary alarm output (dual change over switch contacts) are provided. For the remote control either ASCII string based commands as well as addressable, packet based commands are provided.

Due to the industry standard interfaces, units from other manufacturers can quite easily be replaced.

A separate 19" rack mount remote control unit allows remote control of one or more units. The front panel of this unit is similar to the front panel of the 19" rack mount type.

SPECIALS AND OEM PRODUCTS

WORK is specialized to offer custom tailored products. More than 40% of our converters are sold as OEM products with our customer's brand name and logo on it.

We offer specials as follows:

- Modified or smaller housings
- Dual- or Quad-Band version
- Different IF or RF frequency, a Ka-Band (28GHz) version is under development
- Switchable IF 70 MHz and 140 MHz available
- Customized M&C interface and control syntax
- Extended storage or operating temperature range
- Military versions for hostile environment (shock, vibration, humidity)

KEY FEATURES

- Versions with 70 MHz or 140 MHz IF bands
- Low power consumption typical 35 VA / 27 W (single band unit) 37VA / 29W (triple band units)
- Extreme low phase noise (< -50 dBc/Hz @10 Hz)
- Long term stability 10^{-7} / year

- Output power +10 dBm (1dB compression point)
- Low spurious emissions < - 80 dBm at full gain (high performance series)
- Adjustable equalizer ± 2.5 dB / 40 MHz
- Digital gain compensation
- Operating temperature range -30°C to 60°C (-22°F to 140°F), storage temperature -50°C to 80°C (-58°F to 140°F)
- Remote control (RS232 and RS422/485 interfaces)
- Packet command syntax supports 2-wire or 4-wire bus systems and allows addressed operation
- Summary alarm output (dual change over switch contacts) and transmit mute input
- IP 67 protected housing
- CE compliant
- **3 years warranty**

ORDER INFORMATION

For the Outdoor version only the High Performance type is available due to environmental conditions which require the extended temperature range.

OPEN QUESTIONS, DEMO UNITS

If you need more information about WORK's new 4th satellite converter generation or if you would like to have a demo unit, please contact us via e-mail: sales@work-gmbh.de or call us. We are glad to assist you.

PHYSICAL DIMENSIONS:

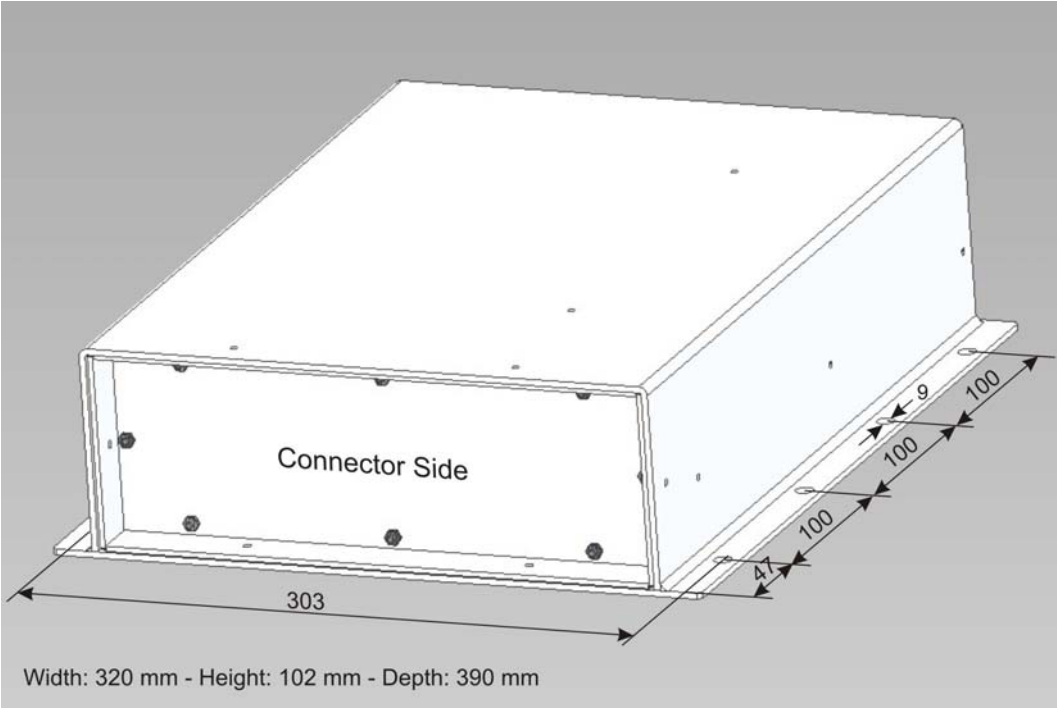

Upconverters High Performance Type (H..), Outdoor Version Parameters depending on RF Frequency Bands

Triband Upconverter Type:	HCU-CXKu, HCU-CKuK																																																			
Dualband Upconverter Type:	Please contact factory																																																			
Singleband Upconverter Type:	HCU-C-OD	HCU-X-OD	HCU-Ku-OD	HCU-Ka-OD**																																																
RF-Output Frequency:	C-Band 5.85...6.65 GHz	X-Band 7.90...8.40 GHz	Ku-Band 12.75...14.50 GHz	Ka-Band 29.7...31.5 GHz																																																
Intermediate Frequency:	2450 MHz for 70 MHz IF Input 2440 MHz for 140 MHz IF Input	2450 MHz for 70 MHz IF Input 2440 MHz for 140 MHz IF Input	2450 MHz for 70 MHz IF Input 2440 MHz for 140 MHz IF Input	2450 MHz for 70 MHz IF Input 2440 MHz for 140 MHz IF Input																																																
Phase Noise:	<table border="0"> <tr> <td>10 Hz</td> <td>-55</td> <td>-69²⁾</td> <td>-53</td> <td>-67²⁾</td> <td>-50</td> <td>-64²⁾</td> <td>-56</td> </tr> <tr> <td>100 Hz</td> <td>-75</td> <td>-79²⁾</td> <td>-73</td> <td>-77²⁾</td> <td>-70</td> <td>-74²⁾</td> <td>-66</td> </tr> <tr> <td>1 kHz</td> <td>-85</td> <td>-89²⁾</td> <td>-83</td> <td>-87²⁾</td> <td>-80</td> <td>-84²⁾</td> <td>-76</td> </tr> <tr> <td>10 kHz</td> <td>-95</td> <td>-99²⁾</td> <td>-93</td> <td>-97²⁾</td> <td>-90</td> <td>-94²⁾</td> <td>-86</td> </tr> <tr> <td>100 kHz</td> <td>-100¹⁾</td> <td>-101²⁾¹⁾</td> <td>-98¹⁾</td> <td>-99²⁾¹⁾</td> <td>-95¹⁾</td> <td>-96²⁾¹⁾</td> <td>-88¹⁾</td> </tr> <tr> <td>1 MHz</td> <td>-110¹⁾</td> <td>-114²⁾¹⁾</td> <td>-108¹⁾</td> <td>-112²⁾¹⁾</td> <td>-105¹⁾</td> <td>-109²⁾¹⁾</td> <td>-101¹⁾</td> </tr> </table>				10 Hz	-55	-69 ²⁾	-53	-67 ²⁾	-50	-64 ²⁾	-56	100 Hz	-75	-79 ²⁾	-73	-77 ²⁾	-70	-74 ²⁾	-66	1 kHz	-85	-89 ²⁾	-83	-87 ²⁾	-80	-84 ²⁾	-76	10 kHz	-95	-99 ²⁾	-93	-97 ²⁾	-90	-94 ²⁾	-86	100 kHz	-100 ¹⁾	-101 ²⁾¹⁾	-98 ¹⁾	-99 ²⁾¹⁾	-95 ¹⁾	-96 ²⁾¹⁾	-88 ¹⁾	1 MHz	-110 ¹⁾	-114 ²⁾¹⁾	-108 ¹⁾	-112 ²⁾¹⁾	-105 ¹⁾	-109 ²⁾¹⁾	-101 ¹⁾
10 Hz	-55	-69 ²⁾	-53	-67 ²⁾	-50	-64 ²⁾	-56																																													
100 Hz	-75	-79 ²⁾	-73	-77 ²⁾	-70	-74 ²⁾	-66																																													
1 kHz	-85	-89 ²⁾	-83	-87 ²⁾	-80	-84 ²⁾	-76																																													
10 kHz	-95	-99 ²⁾	-93	-97 ²⁾	-90	-94 ²⁾	-86																																													
100 kHz	-100 ¹⁾	-101 ²⁾¹⁾	-98 ¹⁾	-99 ²⁾¹⁾	-95 ¹⁾	-96 ²⁾¹⁾	-88 ¹⁾																																													
1 MHz	-110 ¹⁾	-114 ²⁾¹⁾	-108 ¹⁾	-112 ²⁾¹⁾	-105 ¹⁾	-109 ²⁾¹⁾	-101 ¹⁾																																													
	max. values in dBc/ Hz ¹⁾ 0°C to 50°C, outside this temperature range degraded by max 5 dB. ²⁾ with option: low phase noise																																																			
Test Output: (Fixed Oscillator)	2520 MHz (70 MHz IF) 2580 MHz (140 MHz IF) -6 ± 3 dBm SMA female	2520 MHz (70 MHz IF) 2580 MHz (140 MHz IF) -6 ± 3 dBm SMA female	2520 MHz (70 MHz IF) 2580 MHz (140 MHz IF) -6 ± 3 dBm SMA female	2380 MHz (70 MHz IF) 2310 MHz (140MHzIF) -6 ± 3 dBm SMA female																																																
Test Output: (Microwave Oscillator)	8.30...9.10 GHz (70 MHz IF) 8.29...9.09 GHz (140 MHz IF) -7 ± 3 dBm SMA female	10.35...10.85 GHz (70 MHz IF) 10.34...10.84 GHz (140 MHz IF) -7 ± 3 dBm SMA female	15.20...16.95 GHz (70 MHz IF) 15.19...16.94 GHz (140 MHz IF) -7 ± 3 dBm SMA female	27.25...29.05 GHz (70 MHz IF) 27.26...29.06 GHz (140 MHz IF) -10 ± 3 dBm SMA female																																																

** for Ka-Band please contact factory

Upconverters High Performance Type (H..) and Standard Type (S..), Indoor Version Parameters depending on RF Frequency Bands

Singleband Upconverter Type:	HCU-S-OD	HCU-K-OD																								
RF-Output Frequency:	S-Band 2.025...2.110 GHz	K-Band 17.3...18.4 GHz																								
Intermediate Frequency:	2450 MHz for 70 MHz IF Input 2440 MHz for 140 MHz IF Input	2450 MHz for 70 MHz IF Input 2440 MHz for 140 MHz IF Input																								
Phase Noise:	<table border="0"> <tr> <td>10 Hz</td> <td>-60</td> <td>-50</td> <td>-64²⁾</td> </tr> <tr> <td>100 Hz</td> <td>-80</td> <td>-70</td> <td>-74²⁾</td> </tr> <tr> <td>1 kHz</td> <td>-90</td> <td>-80</td> <td>-84²⁾</td> </tr> <tr> <td>10 kHz</td> <td>-100</td> <td>-90</td> <td>-94²⁾</td> </tr> <tr> <td>100 kHz</td> <td>-105¹⁾</td> <td>-95¹⁾</td> <td>-96²⁾¹⁾</td> </tr> <tr> <td>1 MHz</td> <td>-112¹⁾</td> <td>-105¹⁾</td> <td>-109²⁾¹⁾</td> </tr> </table>		10 Hz	-60	-50	-64 ²⁾	100 Hz	-80	-70	-74 ²⁾	1 kHz	-90	-80	-84 ²⁾	10 kHz	-100	-90	-94 ²⁾	100 kHz	-105 ¹⁾	-95 ¹⁾	-96 ²⁾¹⁾	1 MHz	-112 ¹⁾	-105 ¹⁾	-109 ²⁾¹⁾
10 Hz	-60	-50	-64 ²⁾																							
100 Hz	-80	-70	-74 ²⁾																							
1 kHz	-90	-80	-84 ²⁾																							
10 kHz	-100	-90	-94 ²⁾																							
100 kHz	-105 ¹⁾	-95 ¹⁾	-96 ²⁾¹⁾																							
1 MHz	-112 ¹⁾	-105 ¹⁾	-109 ²⁾¹⁾																							
	max. values in dBc/ Hz ¹⁾ 0°C to 50°C, outside this temperature range degraded by max 5 dB. ²⁾ with option: low phase noise																									
Test Output: (Fixed Oscillator)	2520 MHz (70 MHz IF) 2580 MHz (140 MHz IF) -6 ± 3 dBm SMA female	2380 MHz (70 MHz IF) 2300 MHz (140MHzIF) -6 ± 3 dBm SMA female																								
Test Output: (Microwave Oscillator)	4.475...4.560 GHz (70 MHz IF) 4.465...4.540 GHz (140 MHz IF) -7 ± 3 dBm SMA female	14.85...15.95 GHz (70 MHz IF) 15.86...15.96 GHz (140 MHz IF) -7 ± 3 dBm SMA female																								

Specifications are subject to change

**S-Band: 2.025 – 2.290 GHz on request

Other frequency bands on request

Upconverters High Performance Type (H..), Outdoor Version Common Parameters

Conversion Scheme:	Dual up-conversion, no frequency inversion (optional: frequency inversion or switchable)	
Frequency Resolution:	10 Hz	
IF-Input Characteristics:	Frequency: Impedance: Return Loss: IF-Connectors:	70 ± 20 MHz or 140 ± 40 MHz (optional: both → [IF-Band] = 70/140) 50 or 75 Ω 26 dB min 50 Ω: SMA female, 75 Ω: N female
RF-Output Characteristics:	Impedance: Return Loss: 1 dB Compression Point: Output Muting: RF-Signal Monitor: RF-Connectors:	50 Ω >20 dB >10 dBm >60 dB (by command or sense input or by alarm condition) -20 dB of RF-output SMA female
Transfer Characteristics:	Max. Conversion Gain: Attenuation Range: Gain Accuracy: Level Stability: Amplitude Response: Image Rejection: Noise Figure:	40 dB 0...30 dB, Step 0.1 dB (Conversion Gain 40...10 dB) ± 1 dB ± 0.25 dB/day (constant temperature) ± 0.25 dB / ±20 MHz, ±0.2 dB / ± 18 MHz >80 dB <25 dB, 20 dB typical
Equalizer (Gain Slope):	± 2.5 dB / 40 MHz (programmable)	
Group Delay (± 18 MHz):	Linear: Parabolic: Ripple:	0.03 ns / MHz max. 0.01 ns / MHz ² max. 1 ns peak to peak max.
Group Delay (± 36 MHz):	Linear: Parabolic: Ripple:	0.015 ns / MHz max. 0.005 ns / MHz ² max. 2 ns peak to peak max.
Intermodulation (3rd Order):	36 dBc min (f _{in} : 67.5 and 72.5 MHz, P _{in} : 2 x -25 dBm, P _{out} : 2 x 0 dBm)	
AM / PM conversion:	0.1° / dB (P _{out} = 0 dBm)	
Spurious Outputs:	Signal related: Signal independent:	< - 60 dBc (Δf < 1 MHz), < -70 dBc (Δf ≥ 1 MHz) < - 70 dBm
Frequency Stability:	± 1 x 10 ⁻⁷ , 0°C to 50°C ± 2 x 10 ⁻⁸ , 0°C to 50°C (after 30 min warm up) ± 5 x 10 ⁻⁹ per day (fixed temperature after 24 h warm up)	
Reference Input: (optional)	Frequency: Level: Modes: Connector:	10 MHz or 5 MHz -3...10 dBm internal, external, auto (senses reference input) SMA female
Reference Output: (optional)	Frequency: Level: Connector:	10 MHz 0 ± 3 dBm SMA female
Monitoring and Control Interface:	Remote Control : RS232 and RS422/RS485 Alarm Output: Two potential free contacts (DPDT) 24 V DC output: max 0,3 A 6.5 V DC output: max 0,2 A Mute Input: TTL logic input with internal pull up (Connector Type: MIL-C-26482: MS 3120 E 14-19 S)	
Temperature Range:	-30°C to 60°C operating (10 minutes warm up at -30°C) - 30°C to 80°C storage	
Relative Humidity:	100%	
Power Supply:	85...264 V AC, 40...70 Hz	
Power Consumption:	Max: 33 VA / 20 W Typ: 29 VA / 18 W	
Mains Fuse:	2 x 3.15 A time-lag fuse	
Mains Power Input:	Amphenol: C16-1 male	
Dimension and Weight:	390 x 102 x 320 mm ³ , approx. 8.1 kg	
Degree of Protection	IP 67 (acc. IEC 529)	

Specifications are subject to change

Order Information:	HCU-[RF Band]-OD-[IF Band]-[IF Imp] Example: HCU-C-OD-70-50
---------------------------	--

Downconverter High Performance Type (H.), Outdoor Version				
Parameters depending on RF Frequency Bands				
Triband Downconverter Type:	HCD-CXKu			
Dual Band Downconverter Type:	Please contact factory			
Singleband Downconverter Type:	HCD-S-OD	HCD-C-OD	HCD-X-OD	HCD-Ku-OD
RF-Input Frequency:	S-Band 2.2...2.3 GHz**	C-Band 3.4...4.2 GHz	X-Band 7.25...7.75 GHz	Ku-Band 10.70...12.75 GHz
Intermediate Frequency:	2450 MHz for 70 MHz IF Output 2440 MHz for 140 MHz IF Output	2150 MHz for 70 MHz IF Output 2140 MHz for 140 MHz IF Output	2150 MHz for 70 MHz IF Output 2140 MHz for 140 MHz IF Output	2150 MHz for 70 MHz IF Output 2140 MHz for 140 MHz IF Output
Phase Noise:	10 Hz 100 Hz 1 kHz 10 kHz 100 kHz 1 MHz	-60 -80 -90 -96 -105 ¹⁾ -112 ¹⁾	-56 -71 ²⁾ -76 -81 ²⁾ -86 -91 ²⁾ -96 -101 ²⁾ -101 ¹⁾ -103 ²⁾¹⁾ -111 ¹⁾ -116 ²⁾¹⁾	-53 -68 ²⁾ -73 -78 ²⁾ -83 -88 ²⁾ -93 -98 ²⁾ -98 ¹⁾ -100 ²⁾¹⁾ -108 ¹⁾ -113 ²⁾¹⁾
	max. values in dBc/ Hz ¹⁾ 0°C to 50°C, outside this temperature range degraded by max 5 dB. ²⁾ with option: low phase noise			
Test Output (Fixed Oscillator):	2520 MHz (70 MHz IF) 2580 MHz (140 MHz IF) -6 ± 3 dBm, Connector SMA female	2220 MHz (70 MHz IF) 2280 MHz (140 MHz IF) -6 ± 3 dBm, Connector SMA female	2220 MHz (70 MHz IF) 2280 MHz (140 MHz IF) -6 ± 3 dBm, Connector SMA female	2220 MHz (70 MHz IF) 2280 MHz (140 MHz IF) -6 ± 3 dBm, Connector SMA female
Test Output (Microwave Oscillator):	4.65...4.75 GHz (70 MHz IF) 4.64...4.74 GHz (140 MHz IF) -7 ± 3 dBm SMA female	5.55...6.35 GHz (70 MHz IF) 5.54...6.34 GHz (140 MHz IF) -7 ± 3 dBm SMA female	9.40...9.90 GHz (70 MHz IF) 9.39...9.89 GHz (140 MHz IF) -7 ± 3 dBm SMA female	12.85...14.90 GHz (70 MHz IF) 12.84...14.89 GHz (140 MHz IF) -7 ± 3 dBm SMA female

Specifications are subject to change

**S-Band: 2.025 – 2.290 GHz on request

Other frequency bands on request

Downconverter High Performance Type (H.), Outdoor Version		
Common Parameters		
Conversion Scheme:	Dual down-conversion, no frequency inversion (optional: frequency inversion or switchable)	
Frequency Resolution:	10 Hz	
RF-Input Characteristics:	Impedance: Return Loss: Max. input level: LO Leakage: RF-Connector:	50 Ω >20 dB < approx. -25 dBm (operational) < approx. +10 dBm (damage level) -80 dBm max. SMA female
IF-Output Characteristics:	Frequency: Impedance: Return Loss: 1 dB Compression Point: Output Muting: IF-Signal Monitor: IF-Connectors:	70 ± 20 MHz or 140 ± 40 MHz (optional: both → [IF-Band] = 70/140) 50 or 75 Ω 26 dB min >10 dBm, 13 dBm typical >60 dB (by command or sense input or by alarm condition) -20 dB of IF-output 50 Ω: SMA female, 75 Ω: N female
Transfer Characteristics:	Max. Conversion Gain: Attenuation Range: Gain Accuracy: Level Stability: Amplitude Response: Image Rejection: Noise Figure:	45 dB 0...30 dB, Step 0.1 dB (Conversion Gain 45...15 dB) ± 1 dB ± 0.25 dB/day (constant temperature) ± 0.25 dB / ±20 MHz, ±0.2 dB / ± 18 MHz >80 dB <12 dB, 10 dB typical
Equalizer (Gain Slope):	± 2.5 dB / 40 MHz (programmable)	
Group Delay (± 18 MHz):	Linear: Parabolic: Ripple:	0.03 ns / MHz max. 0.01 ns / MHz ² max. 1 ns peak to peak max.
Group Delay (± 36 MHz):	Linear: Parabolic: Ripple:	0.015 ns / MHz max. 0.005 ns / MHz ² max. 2 ns peak to peak max.
Intermodulation (3rd Order):	60 dBc min (Δf _{in} : 5 MHz, P _{in} : 2 x -40 dBm, P _{out} : 2 x -10 dBm)	
AM / PM conversion:	0.1° / dB (P _{out} = 0 dBm)	
Spurious Outputs:	Signal related: Signal independent:	< -60 dBc (Δf < 1 MHz), < -70 dBc (Δf ≥ 1 MHz) < -76 dBm (< -80 dBm typical)
Frequency Stability:	± 1 x 10 ⁻⁷ , 0°C to 50°C ± 2 x 10 ⁻⁸ , 0°C to 50°C (after 30 min warm up) ± 5 x 10 ⁻⁹ per day (fixed temperature after 24 h warm up)	
Reference Input (optional)	Frequency: Level: Modes: Connector:	10 MHz or 5 MHz -3...10 dBm internal, external, auto (senses reference input) SMA female
Reference Output (optional)	Frequency: Level: Connector:	10 MHz 0 ± 3 dBm SMA female

Monitoring and Control Interface:	Remote Control : RS232 and RS422/RS485 Alarm Output: Two potential free contacts (DPDT) 24 V DC output: max 0,3 A 6.5 V DC output: max 0,2 A Mute Input: TTL logic input with internal pull up (Connector Type: MIL-C-26482: MS 3120 E 14-19 S)
Temperature Range:	-30°C to 60°C operating (10 minutes warm up at -30°C) - 30°C to 80°C storage
Relative Humidity:	100%
Power Supply:	85...264 V AC, 40...70 Hz
Power Consumption:	Max: 33 VA / 20 W Typ: 29 VA / 18 W
Mains Fuse:	2 x 3.15 A time-lag fuse
Mains Power Input:	Amphenol: C16-1 male
Dimension and Weight:	390 x 102 x 320 mm ³ , approx. 8.1 kg
Degree of Protection	IP 67 (acc. IEC 529)

Specifications are subject to change

Order Information:	HCD-[RF Band]-OD-[IF Band]-[IF Imp] Example: HCD-C-OD-140-50
---------------------------	---

Compact Satellite Upconverter C-, X-, Ku-, K-Band



Module



WORK is offering compact satellite upconverter modules with 70 MHz or 140 MHz IF input frequency, dual 70 or 140 MHz IF is an option.

The output frequency band is either the C-, X-, Ku- or K-Band.

They are suitable as OEM product for easy integration into:

- Standard 19" rack mount converter units
- High power amplifiers (TWTA's or SSPA's)
- Satellite news gathering equipment (SNG)
- Mobile satellite communication equipment (Fly-Aways)

The extreme low phase noise of the oscillators guarantees a very good signal quality. Low spurious emissions allow to use the converters also in demanding environments, like high power broadcast uplinks. Sophisticated temperature compensation guarantees gain stability over a very wide temperature range.

KEY FEATURES

- Small housing
- Synthesized upconverter with 10 Hz step size
- RF output filter included
- Internal OCXO with high long term stability 10^{-7} / year
- Output power +10 dBm (1dB compression point)
- Low spurious emissions
- No spectral inversion
- Adjustable equalizer ± 2.5 dB / 40 MHz
- Low power consumption typ. less than 20 W
- Operating temperature range -30°C to 60°C
- Remote control (RS232 or RS422/485)
- Packet command syntax supports 2-wire or 4-wire bus systems and allows addressed operation
- Summary alarm output (change over switch contact)
- Transmit mute input

Compact Single-Band Upconverter, Specification High Performance Type, Module				
Upconverter Type:	HCU-C-M	HCU-X-M	HCU-Ku-M	HCU-K-M
RF-Output Frequency:	C-Band 5.85.. 6.65 GHz	X-Band 7.90.. 8.40 GHz	Ku-Band 12.75.. 14.5 GHz	K-Band 17.3.. 18.4 GHz
Frequency Resolution:	10 Hz			
Conversion Scheme:	Dual up-conversion (IF1 = 2450 MHz), no frequency inversion			
IF-Input Characteristics:	Frequency: 70 ± 20 MHz or 140 ± 40 MHz Impedance: 50 Ω Return Loss: 26 dB min IF-Signal Monitor: -20 dB of IF-Input IF-Connectors: SMA female			
RF-Output Characteristics:	Impedance: 50 Ω Return Loss: >20 dB 1 dB Compression Point: >10 dBm Output Muting: >60 dB (by command or sense input or by alarm condition) RF-Connector: SMA female			
Transfer Characteristics:	Max. Conversion Gain: 40 dB Attenuation Range: 0...30 dB, Step 0.1 dB (Conv. Gain 40...10 dB) Gain Accuracy: ± 1 dB Level Stability: ± 0.25 dB/day (constant temperature) Amplitude Response: ± 0.25 dB / ±20 MHz, ±0.2 dB / ± 18 MHz Image Rejection: >80 dB Noise Figure: <25 dB, 20 dB typical			
Equalizer (Gain Slope):	± 2.5 dB / 40 MHz (programmable)			
Group Delay (± 18 MHz):	Linear: 0.03 ns / MHz max. Parabolic: 0.01 ns / MHz ² max. Ripple: 1 ns peak to peak max.			
Group Delay (± 36 MHz):	Linear: 0.015 ns / MHz max. Parabolic: 0.005 ns / MHz ² max. Ripple: 2 ns peak to peak max.			
Intermodulation (3rd Order):	36 dBc min (f _{in} : 67.5 and 72.5 MHz, P _{in} : 2 x -25 dBm, P _{out} : 2 x 0 dBm)			
AM / PM conversion:	0.1° / dB (P _{out} = 0 dBm)			
Phase Noise:	10 Hz - 50 dBc/Hz 100 Hz - 70 dBc/Hz 1 kHz - 80 dBc/Hz 10 kHz - 90 dBc/Hz 100 kHz - 95 dBc/Hz ¹⁾ 1 MHz - 105 dBc/Hz ¹⁾ ¹⁾ 0°C to 50°C, outside this temperature range degraded by max 5 dB.			
Spurious Outputs:	Signal related: < - 60 dBc (Δf < 1 MHz), < -70 dBc (Δf ≥ 1 MHz) Signal independent: < - 70 dBm			
Frequency Stability:	± 1 x 10 ⁻⁷ , 0°C to 50°C ± 2 x 10 ⁻⁸ , 0°C to 50°C (after 30 min warm up) ± 5 x 10 ⁻⁹ per day (fixed temperature after 24 h warm up)			
Reference Input:	Frequency: 10 MHz or 5 MHz Level: -5...10 dBm Modes: internal, external, auto (senses reference input) Connector: BNC female			
Reference Output:	Frequency: 10 MHz Level: 0 ± 3 dBm Connector: BNC female			
Test Output (Fixed Oscillator), (Option):	2520 MHz (70 MHz IF) 2590 MHz (140 MHz IF) 0 ± 3 dBm SMA female	2520 MHz (70 MHz IF) 2590 MHz (140 MHz IF) 0 ± 3 dBm SMA female	2520 MHz (70 MHz IF) 2590 MHz (140 MHz IF) 0 ± 3 dBm SMA female	2380 MHz (70 MHz IF) 2310 MHz (140 MHz IF) 0 ± 3 dBm SMA female
Test Output (Microwave Oscillator), (Option):	8.30...9.10 GHz - 7 ± 3 dBm SMA female	10.35...10.85 GHz - 7 ± 3 dBm SMA female	15.20...16.95 GHz - 7 ± 3 dBm SMA female	14.85...15.95 GHz - 7 ± 3 dBm SMA female
Monitoring and Control Interface:	RS232, (RS422/RS485 Option) (Connector DSUB09 female)			
DC/ Alarm Interface:	DC Power Input Alarm Output: potential free contact (DPDT) Mute Input: TTL logic input with internal pull up (Connector DSUB09 male)			
Power Input, Consumption	24 V DC, 2 A			
Temperature Range:	-30°C to 60°C operating (10 minutes warm up at -30°C) -50°C to 80°C storage			
Relative Humidity:	< 95 % non condensing			
Dimension and Weight:	L x W x H: 260 x 190 x 37 mm, 2 kg (approx)			

Order Information:	HCU-[RF Band]-[IF Band]-M Example: HCU-C-70-M or HCU-Ku-140-M
---------------------------	--

Specifications are subject to change

20041001

Satellite High Speed DVB Modulator-Upconverter C-, X-, Ku-, K-Band



Indoor Version



The new satellite high speed DVB modulator / upconverter series combines WORK's new 4th generation upconverters with an improved high-speed DVB modulator in one housing only. This combination offers a cost and space saving solution. No extra modulator is required. The unit can be used in fixed satellite ground stations as well as in satellite news gathering (SNG) vehicles, Fly-Aways or any other mobile or portable applications (we offer special housings for complete applications, see next page "SPECIALS AND OEM PRODUCTS").

NEW APPROACH- BETTER SOLUTION

For all high power TV-uplink which require low spurious emissions, two separate units were needed, a modulator plus a conventional upconverter.

WORK's new modulator / converter concept allows both units in one housing. This approach provides a very low spurious signal over the whole frequency band. For example for the Ku-Band we cover the complete frequency range from 12.75-14.50 GHz with one unit only, for other bands as well. This is a significant advantage compared to the combination L-Band modulator / blockconverter. Next these technical benefit we can even offer lower prices compared to the block converter/modulator solution.

STANDARD MPEG/DVB DATA INPUT

The units accept the MPEG/DVB digital video transport stream from a video encoder or MPEG multiplexer and connect directly to a high power amplifier. If more than one digital carrier shall be transmitted, then the signals can be combined in the RF frequency band.

HIGH SIGNAL INTEGRITY

The high speed, variable rate digital modulator with frequency agile RF output signal provides a modulated carrier signal in the C-Band, Ku-Band or K-Band frequency range. Low spurious emissions allow using the modulator-upconverters also in environments with demanding requirements, like high power video uplinks. Sophisticated temperature compensation guarantees gain stability over a very wide temperature range.

Framing, scrambling, FEC encoding and QPSK modulation is compliant with the DVB standard EN 300421. The high bandwidth efficient modulation modes 8PSK and 16QAM are compliant with the DVB standard EN 301210. BPSK modulation is also possible. Symbol rates up to 60 Msps are supported.

OPERATING AND CONTROL - EASY INTEGRATION INTO YOUR SYSTEM

The converters can be operated via the push buttons on the front panel using self-explanatory display menus or via remote control (RS232, RS422/485, TCP/IP over Ethernet).

Detailed monitoring of the system status and a summary alarm output (dual change over switch contacts) are provided. For the remote control either ASCII string based commands as well as addressable, packet based commands are provided.

Due to the industry standard interfaces, units from other manufacturers can quite easily be replaced.

SPECIALS AND OEM PRODUCTS

WORK is specialized to offer custom tailored products. More than 40% of our converters are sold as OEM products with our customer's brand name and logo on it.

We offer specials as follows:

- Modified or smaller housings to fit into your existing design
- Different front panels with ten digit keypad
- Dual- or Quad-Band versions
- Different RF frequency, a Ka-Band (28 GHz) version is under development
- Customized M&C interface and control syntax
- Extended storage or operating temperature range.
- Military versions for hostile environment (shock, vibration, humidity)

KEY FEATURES

- DVB compatible modulator for digital TV satellite uplink and digital SNG applications
- Operating temperature range either -30°C to 60°C (-22°F to 140°F) or 0°C to 50°C (32°F to 122°F)
- Symbol rate up to 60 Msps
- Low spurious output
- ASI and SPI electrical interfaces
- ASI optical interface (option)
- Modulation BPSK, QPSK, 8PSK and 16QAM
- All popular DVB compatible FEC-coding schemes supported
- Compliant to DVB (EN 300421) modulation 8PSK and 16QAM compliant to DVB (EN 301210)

- Adjustable digital slope equalizer
- Test output of modulated signal at 1.0 GHz (option)
- Summary alarm output (dual change over switch contacts)
- Transmit mute input
- Password upgradeable firmware options: QL, QH, PL, PH
- CE compliant
- **3 years warranty**

ORDER INFORMATION

WORK offers two series of 19" rack satellite converters / modulators, the Standard and High Performance Type. The specifications are the same for both types except the operating temperature range. The High Performance Type operates between -30°C to 60°C (-22°F to 140°F) and the Standard Type between 0°C to 50°C (32°F to 122°F). The power consumption is maximum only 35 VA / 27 W in both versions. So if you only need units for inside use, the standard unit is perfectly suited for this application and it is significantly cheaper.

Customer field selectable Firmware

In order to meet your requirements different maximum symbol rates and different sets of modulation types are supported depending on the selected firmware option -QL, -QH, -PL or -PH. The firmware option is password upgradeable in the field, which allows easy enhancement of the modulators if requirements change.

Summary of firmware options:

Firmware Option	Max Symbol Rate, Supported Modulation Types
- QL	20 Msps, BPSK/QPSK
- QH	60 Msps, BPSK/QPSK
- PL	20 Msps, BPSK/QPSK/8PSK/16QAM
- PH	60 Msps, BPSK/QPSK/8PSK/16QAM

OPEN QUESTIONS, DEMO UNITS

If you need more information about WORK's new 4th satellite converter generation or if you would like to have a demo unit, please contact us via e-mail: sales@work-gmbh.de or call us. We are glad to assist you.

DVB Modulator-Upconverter Specification High Performance Type (H..) and Standard Type (S..), Indoor Version				
Modulator-Upconverter Type:	HMCU-C / SMCU-C	HMCU-X	HMCU-Ku / SMCU-Ku	HMCU-K / SMCU-K
RF-Output Frequency:	C-Band 5.85...6.65 GHz	X-Band 7.90...8.40 GHz	Ku-Band 12.75...14.5 GHz	K-Band 17.3...18.4 GHz
Frequency Resolution:	10 Hz			
Conversion Scheme:	IQ-Modulator at 2450 MHz, single up-conversion			
RF-Output Characteristics:	Impedance: Return Loss: Output Power: Output Muting: RF-Signal Monitor: RF-Connectors:	50 Ω >20 dB - 25 dBm to +5 dBm, 0.1 dB steps >70 dB (by command or sense input or by alarm condition) -20 dB of RF-output (optional) SMA female		
Spurious Outputs:	Signal related: Signal independent:	< - 70 dBc (Pout > - 20 dBm) < - 65 dBc (Pout ≤ - 20 dBm)		
Phase Noise:	10 Hz 100 Hz 1 kHz 10 kHz 100 kHz 1 MHz	- 50 dBc/Hz - 70 dBc/Hz - 80 dBc/Hz - 85 dBc/Hz ¹⁾ - 95 dBc/Hz ¹⁾ -105 dBc/Hz ¹⁾	1) 0°C to 50°C, outside this temperature range degraded by appr. 5 dB.	
Frequency Stability:	± 1 x 10 ⁻⁷ , 0°C to 50°C ± 2 x 10 ⁻⁸ , 0°C to 50°C (after 30 min warm up) ± 5 x 10 ⁻⁹ per day (fixed temperature after 24 h warm up)			
Reference Input:	Frequency: Level: Modes: Connector:	10 MHz or 5 MHz -5...10 dBm internal, external, auto (senses reference input) BNC female		
Symbol Rate:	Firmware Option QL,PL: Firmware Option QH,PH: Step Size:	20 Msps 60 Msps 1 sps		
Clock Stability:	± 1 x 10 ⁻⁷ , 0°C to 50°C			
Data Rate:	40 kbps - 193 Mbps (depending on firmware option, modulation and inner coding)			
Outer Coding	Reed Solomon (188/204, T=8)			
Inner Coding and Modulation:	Firmware Option QL,QH,PL,PH: Firmware Option PL,PH:	BPSK or QPSK 1/2, 2/3, 3/4, 5/6, 6/7, 7/8 (Convolutional K=7) 8PSK 2/3, 5/6, 8/9 (Pragmatic Trellis) 16QAM 3/4, 7/8 (Pragmatic Trellis)		
Roll Off Factor:	α = 0,25 or α = 0,35			
Transport Stream Input Interface:	DVB-SPI (DSUB25 female) DVB-ASI-electrical (Connector BNC female 50 Ohm, Impedance 75 Ohm) DVB-ASI-optical (Connector ST female, Multimode, 1300 nm) (Option)			
Transport Stream Frames Size:	188 bytes or 204 bytes			
Packet Stuffing:	Null packet insertion, when the transmission rate is higher than the data rate of the data input.			
Transport Stream Adaption and Randomization:	Compliant with EN 300421			
Convolutional Interleaving:	Depth I = 12			
Compliant with DVB Standards:	EN 300421EN 301210 (8PSK, 16QAM, α = 25 %) EN 50083-9 (ASI electrical, SPI Interface)			
Monitoring:	Faults, stored faults with time stamps			
Test Output (Microwave Oscillator):	8.3...9.1 GHz - 7 ± 3 dBm SMA female	10.35...10.85 GHz - 7 ± 3 dBm SMA female	15.2...16.95 GHz - 7 ± 3 dBm SMA female	14.85...15.95 GHz - 7 ± 3 dBm SMA female
Monitoring and Control Interface:	TCP/IP over Ethernet (10 or 100 Mbit/s, auto sensing) RS232 or RS422/RS485 (Connectors DSUB09 female) (configurable by software) Mute Input: TTL logic input with internal pull up			
Alarm Interface:	Two potential free contacts (DPDT, Connector DSUB09 female)			
Temperature Range:	HMCU:-30°C to 60°C operating (10 minutes warm up at -30°C, the LCD display is operational: -20°C to 60°C) SMCU: 0°C to 50°C operating -30°C to 80°C storage			
Relative Humidity:	< 95% non condensing			
User Interface:	LCD, 2 x 40 characters, 4 cursor keys, 4 function keys			
Power Supply:	85...264 V AC, 40...70 Hz			
Dimension and Weight:	483 x 44 x 500 mm ³ , 1 RU (19") appr. 9.6 kg			
Order Information:	HMCU-[RF Band]-[Firmware Opt.] or SMCU-[RF Band]-[Firmware Opt.] Example: HMCU-C-PL or HMCU-Ku-PH			

Specifications are subject to change

Satellite High Speed DVB Modulator-Upconverter C-, X-, Ku-, K-Band



Outdoor Version



The new satellite high-speed DVB modulator / upconverter combines WORK's 4th generation of satellite converter with a improved high speed modulator in an outdoor package for use under all weather conditions. No extra modulator is required. The units operate over temperature range from -30°C to 60°C. It survives a non-operating temperature of -50°C to 80°C without any damage. Due to their rugged construction and very low power consumption they are best fit for satellite news gathering (SNG) vehicles, Fly-Aways or other mobile applications (we offer special housings for compact mobile applications, see next page "SPECIALS AND OEM PRODUCTS".)

NEW APPROACH- BETTER SOLUTION

For all high power TV-uplinks which require low spurious emissions, two separate units were needed in the past, a modulator plus a conventional up-converter.

WORK's new modulator / converter concept allows both units in one housing. This approach provides a very low spurious signal over the whole frequency band. For example for the Ku-Band we cover the complete frequency range from 12.75-14.50 GHz with

one unit only. This is a significant advantage compared to the combination L-Band modulator / blockconverter.

OUTDOOR INSTALLATION

The units are designed for outdoor use, to be mounted directly behind the antenna. They do not require additional protection. The housing provides environmental protection according to IP67 (temporary flooding) when all cables are connected and sealed appropriately. The special environmental protection sleeves for the coaxial connectors allow optimal sealing from the housing to the cable. The housing should be mounted with the connector side down. Alternatively the connector panel can be in a vertical position.

STANDARD MPEG/DVB DATA INPUT

The units accept the MPEG/DVB digital video transport stream from a video encoder or MPEG multiplexer and connect directly to a high power amplifier.

HIGH SIGNAL INTEGRITY

The high speed, variable rate digital modulator with frequency agile RF output signal provides a modulated carrier signal in the C-Band, Ku-Band or K-Band frequency range. Low spurious emissions allow using the modulator / upconverter also in environments with demanding requirements, like high power video uplinks. Sophisticated temperature compensation guarantees gain stability over a very wide temperature range. Framing, scrambling, FEC encoding and QPSK modulation is compliant with the DVB standard EN 300421. The high bandwidth efficient modulation modes 8PSK and 16QAM are compliant with the DVB standard EN 301210. BPSK modulation is also possible. Symbol rates up to 60 Msps are supported.

OPERATING AND CONTROL - EASY INTEGRATION INTO YOUR SYSTEM

The converters can be operated via remote control (RS 232, RS422/485).

Detailed monitoring of the system status and a summary alarm output (dual change over switch contacts) are provided. For the remote control either ASCII string based commands as well as addressable, packet based commands are provided. Due to the industry standard interfaces, units from other manufacturers can quite easily be replaced.

A separate 19" rack mount remote control unit allows remote control of one or more units. The front panel of this unit is similar to the front panel of the 19" rack mount type.

SPECIALS AND OEM PRODUCTS

WORK is specialized to offer custom tailored products. More than 40% of our converters are sold as OEM products with our customer's brand name and logo on it.

We offer specials as follows:

- Modified or smaller housings to fit into your existing design
- Dual- or Quad-Band version
- Different RF frequency, a Ka-Band (28 GHz) version is under development.
- Customized M&C interface and control syntax
- Extended storage or operating temperature range
- Military versions for hostile environment (shock, vibration, humidity)

KEY FEATURES

- DVB compatible modulator for digital TV satellite uplink and digital SNG applications
- Operating temperature range -30°C to 60°C (-22°F to 140°F), storage Temperature -50°C to 80°C (-58°F to 176°F)
- Symbol Rate up to 60 Msps
- Output power up to +5 dBm
- Low spurious output
- ASI electrical interface
- Modulation BPSK, QPSK, 8PSK and 16QAM
- All popular DVB compatible FEC-coding schemes supported
- Compliant to DVB (EN 300421)
- Modulation 8PSK and 16QAM compliant to DVB (EN 301210)
- Adjustable digital slope equalizer
- Optimized for low power consumption and cooling only via convection.
- Summary alarm output (dual change over switch contacts)
- Transmit mute input
- IP 67 protected housing
- Password upgradeable firmware options: QL, QH, PL, PH
- CE compliant
- **3 years warranty**

ORDER INFORMATION

Customer field selectable firmware

In order to meet your requirements different maximum symbol rates and different sets of modulation types are supported depending on the selected firmware option -QL, -QH, -PL or -PH. The firmware option is password upgradeable in the field, which allows easy enhancement of the modulators if requirements change.

Firmware Option	Max Symbol Rate, Supported Modulation Types
- QL	20 Msps, BPSK/QPSK
- QH	60 Msps, BPSK/QPSK
- PL	20 Msps, BPSK/QPSK/8PSK/16QAM
- PH	60 Msps, BPSK/QPSK/8PSK/16QAM

OPEN QUESTIONS, DEMO UNITS

If you need more information about WORK's new 4th satellite converter generation or if you would like to have demo unit, please contact us via e-mail: sales@work-gmbh.de or call us. We are glad to assist you.

PHYSICAL DIMENSIONS

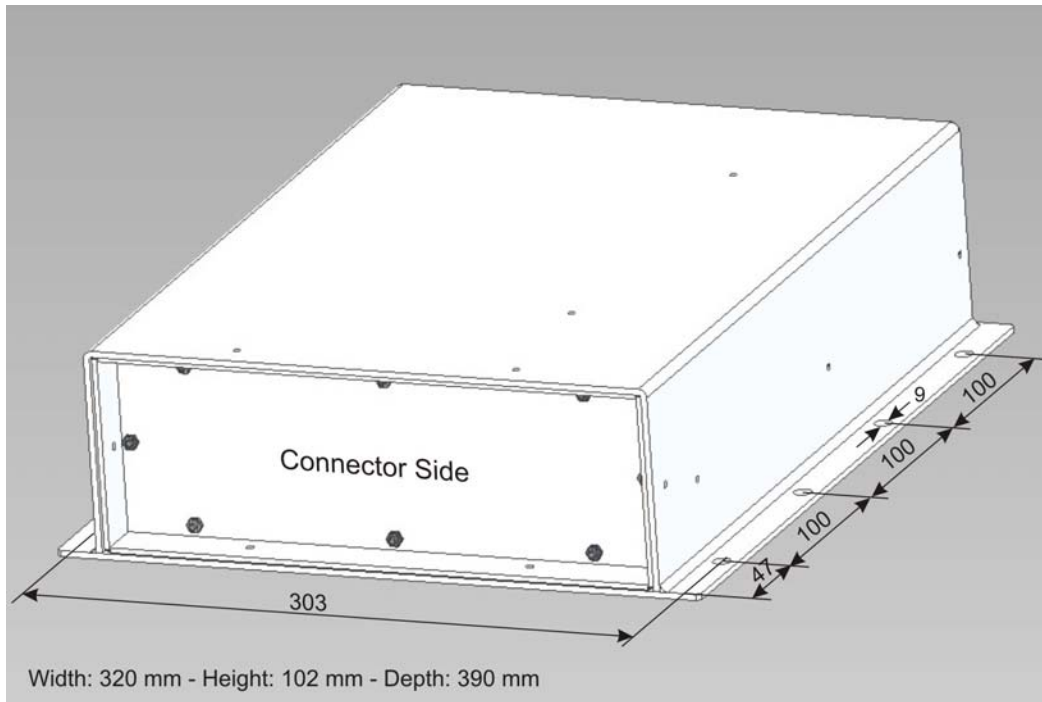

DVB Modulator-Upconverter Specification High Performance Type, Outdoor Version				
Modulator-Upconverter Type:	HMCU-C-OD	HMCU-X-OD	HMCU-Ku-OD	HMCU-K-OD
RF-Output Frequency:	C-Band 5.85...6.65 GHz	X-Band 7.90.. 8.40 GHz	Ku-Band 12.75...14.5 GHz	K-Band 17.3...18.4 GHz
Frequency Resolution:	10 Hz			
Conversion Scheme:	IQ-Modulator at 2450 MHz, single up-conversion			
RF-Output Characteristics:	Impedance: Return Loss: Max Output Power: Output Muting: RF-Connectors:	50 Ω >20 dB - 25 dBm to +5 dBm, 0.1 dB steps >70 dB (by command or sense input or by alarm condition) SMA female		
Spurious Outputs:	Signal related: Signal independent:	< - 70 dBc (Pout > - 20 dBm) < - 65 dBc (Pout ≤ - 20 dBm)		
Phase Noise:	10 Hz 100 Hz 1 kHz 10 kHz 100 kHz 1 MHz	- 50 dBc/Hz - 70 dBc/Hz - 80 dBc/Hz - 85 dBc/Hz - 95 dBc/Hz ¹⁾ -105 dBc/Hz ¹⁾	¹⁾ 0°C to 50°C, outside this temperature range degraded by appr. 5 dB.	
Frequency Stability:	± 1 x 10 ⁻⁷ , 0°C to 50°C ± 2 x 10 ⁻⁸ , 0°C to 50°C (after 30 min warm up) ± 5 x 10 ⁻⁹ per day (fixed temperature after 24 h warm up)			
Symbol Rate:	Firmware Option QL,PL: Firmware Option QH,PH: Step Size:	20 Msps 60 Msps 1 sps		
Clock Stability:	± 1 x 10 ⁻⁷ , 0°C to 50°C			
Data Rate:	40 kbps - 193 Mbps (depending on firmware option, modulation and inner coding)			
Outer Coding	Reed Solomon (188/204, T=8)			
Inner Coding and Modulation:	Firmware Option QL,QH,PL,PH: Firmware Option PL,PH:	BPSK or QPSK 1/2, 2/3, 3/4, 5/6, 6/7, 7/8 (Convolutional K=7) 8PSK 2/3, 5/6, 8/9 (Pragmatic Trellis) 16QAM 3/4, 7/8 (Pragmatic Trellis)		
Roll Off Factor:	α = 0,25 or α = 0,35			
Transport Stream Input Interface:	DVB-ASI-electrical (Connector SMA female 50 Ohm, Impedance 75 Ohm)			
Transport Stream Frames Size:	188 bytes or 204 bytes			
Packet Stuffing:	Null packet insertion, when the transmission rate is higher than the data rate of the data input.			
Transport Stream Adaption and Randomization:	Compliant with EN 300421			
Convolutional Interleaving:	Depth I =12			
Compliant with DVB Standards:	EN 300421 EN 301210 (8PSK, 16QAM, α = 25 %) EN 50083-9 (ASI electrical)			
Monitoring:	Faults, stored faults with time stamps			
Monitoring and Control Interface:	Remote Control : RS232 and RS422/RS485 Alarm Output: Two potential free contacts (DPDT) 24 V DC output: max 0,3 A 6.5 V DC output: max 0,2 A Mute Input: TTL logic input with internal pull up (Connector Type: MIL-C-26482: MS 3120 E 14-19 S)			
Temperature Range:	-30°C to 60° C operating (10 minutes warm up at -30°C) - 50°C to 80°C storage			
Relative Humidity:	100%			
Power Supply:	85...264 V AC, 40...70 Hz 0.9 A max			
Mains Power Input:	Amphenol: C16-1 male			
Dimension and Weight:	390 x 102 x 320 mm ³ , appr. 8.1 kg			
Degree of Protection	IP 67 (acc. IEC 529)			
Order Information	HMCU-[RF Band]-OD-[Firmware Option] or SMCU-[RF Band]-OD-[Firmware Option] Example: HMCU-C-OD-PL			

Specifications are subject to change

Satellite High Speed DVB Modulator



70/140 MHz IF Output L-Band Output



The new satellite high speed DVB modulator with 70 MHz/140 MHz IF or L-Band output provides high flexibility for the station design. The modulator can be integrated in most standard station configurations and can be used in fixed satellite ground stations as well as in satellite news gathering (SNG) vehicles, Fly-Aways or any other mobile or portable applications (we offer special housings for complete applications, see next page "SPECIALS AND OEM PRODUCTS").

STANDARD MPEG/DVB DATA INPUT

The modulator accepts the MPEG/DVB digital video transport stream from a video encoder or MPEG multiplexer and provides a modulated carrier anywhere between 50...180 MHz or L-Band. If more than one digital carrier shall be transmitted, then the signals can be combined in the IF- or L-Band frequency band.

HIGH SIGNAL INTEGRITY

Low spurious emissions allow using the modulator also in environments with demanding requirements, like high power video uplinks. Sophisticated temperature compensation guarantees gain stability over a very wide temperature range.

Framing, scrambling, FEC encoding and QPSK modulation is compliant with the DVB standard EN 300421. The high bandwidth efficient modulation modes 8PSK and 16QAM are compliant with the DVB standard EN 301210. BPSK modulation is also possible. Symbol rates up to 60 Msps are supported.

OPERATING AND CONTROL - EASY INTEGRATION INTO YOUR SYSTEM

The modulator can be operated via the push buttons on the front panel using self-explanatory display menus or via remote control (RS232, RS422/485, IP over Ethernet).

Detailed monitoring of the system status and a summary alarm output (dual change over switch contacts) are provided. For the remote control either ASCII string based commands as well as addressable, packet based commands are provided.

Due to the industry standard interfaces, units from other manufacturers can quite easily be replaced.

SPECIALS AND OEM PRODUCTS

WORK is specialized to offer custom tailored products. More than 40% of our converters are sold as OEM products with our customer's brand name and logo on it.

We offer specials as follows:

- Modified or smaller housings to fit into your existing design
- Different front panels with ten digit keypad
- Dual Modulator units.
- L-Band output.
- Customized M&C interface and control syntax
- Extended storage or operating temperature range.
- Military versions for hostile environment (shock, vibration, humidity)

KEY FEATURES

- DVB compatible modulator for digital TV satellite uplink and digital SNG applications
- Operating temperature range -30°C to 60°C (-22°F to 140°F)
- Symbol rate up to 60 Msps
- Low spurious output
- ASI and SPI electrical interfaces
- ASI optical interface (option)
- Modulation BPSK, QPSK, 8PSK and 16QAM
- All popular DVB compatible FEC-coding schemes supported
- Compliant to DVB (EN 300421) modulation 8PSK and 16QAM compliant to DVB (EN 301210)

- Adjustable digital slope equalizer
- Summary alarm output (dual change over switch contacts)
- Transmit mute input
- An output signal multiplexer integrated within the L-Band version allows to combine the modulated signal, the 10 MHz reference signal and DC power to drive an external block upconverter.
- Password upgradeable firmware options: QL, QH, PL, PH
- CE compliant
- **3 years warranty**

ORDER INFORMATION

Customer field selectable Firmware

In order to meet your requirements different maximum symbol rates and different sets of modulation types are supported depending on the selected firmware option -QL, -QH, -PL or -PH. The firmware option is password upgradeable in the field, which allows easy enhancement of the modulators if requirements change.

Summary of firmware options:

Firmware Option	Max Symbol Rate, Supported Modulation Types
- QL	20 Msps, BPSK/QPSK
- QH	60 Msps, BPSK/QPSK
- PL	20 Msps, BPSK/QPSK/8PSK/16QAM
- PH	60 Msps, BPSK/QPSK/8PSK/16QAM

OPEN QUESTIONS, DEMO UNITS

If you need more information about WORK's new satellite modulator or if you would like to have demo a unit, please contact us via e-mail: sales@work-gmbh.de or call us. We are glad to assist you.

DVB Modulator Specification 70 MHz / 140 MHz or L-Band Output High Performance Type (H..) and Standard Type (S.), Indoor Version			
Modulator Type:	HDM-V / SDM-V		HDM-L / SDM-L
IF-Output Frequency:	50 to 180 MHz		950 MHz to 1950 MHz
Frequency Resolution:	1 Hz		
IF-Output Characteristics:	Impedance: Return Loss: Output Power: Accuracy: Stability: Output Power muted: IF-Connector:	75 Ω (option 50 Ω) (SDM-V / HDM-V) 50 Ω (SDM-L / HDM-L) >20 dB - 25 dBm to +5 dBm, 0.1 dB steps (SDM-V / HDM-V) - 30 dBm to 0 dBm, 0.1 dB steps (SDM-L / HDM-L) ± 0.5 dB ± 0.5 dB < -85 dBm BNC female (SDM-V / HDM-V) SMA female (SDM-L / HDM-L)	
IF-Monitoring Output:	Impedance: Return Loss: Output Power: IF-Monitoring Connector:	50 Ω >20 dB - 20 dB of IF Output SMA female	
Spurious Outputs:	Signal related:	< - 60 dBc / 4 kHz (modulated carrier) < - 60 dBc (unmodulated carrier, in band) < - 45 dBc (unmodulated carrier, out of band)	
Phase Noise:	10 Hz 100 Hz 1 kHz 10 kHz 100 kHz 1 MHz	- 60 dBc/Hz - 75 dBc/Hz - 85 dBc/Hz - 90 dBc/Hz - 100 dBc/Hz - 115 dBc/Hz	exceeds IESS-308/309 by 10 dB min
Frequency Stability:	± 5 x 10 ⁻⁸ (-30°C to 60°C), aging: ± 1 x 10 ⁻⁹ per day, ± 1 x 10 ⁻⁷ per year (SDM-V / HDM-V) ± 5 x 10 ⁻⁸ (-30°C to 60°C), aging: ± 1 x 10 ⁻⁹ per day, ± 1 x 10 ⁻⁷ per year (SDM-L / HDM-L)		
Symbol Rate:	Firmware Option QL,PL: Firmware Option QH,PH: Step size:	20 Msps 60 Msps 1 sps	
Clock Stability:	± 5 x 10 ⁻⁸ (-30°C to 60°C), aging: ± 1 x 10 ⁻⁹ per day, ± 1 x 10 ⁻⁷ per year (SDM-V / HDM-V) ± 5 x 10 ⁻⁸ (-30°C to 60°C), aging: ± 1 x 10 ⁻⁹ per day, ± 1 x 10 ⁻⁷ per year (SDM-L / HDM-L)		
Data Rate:	40 kbps - 193 Mbps (depending on firmware option, modulation and inner coding)		
Outer Coding	Reed Solomon (188/204, T=8)		
Inner Coding and Modulation:	Firmware Option QL,QH,PL,PH: Firmware Option PL,PH:	BPSK or QPSK 1/2, 2/3, 3/4, 5/6, 6/7, 7/8 (Convolutional K=7) 8PSK 2/3, 5/6, 8/9 (Pragmatic Trellis) 16QAM 3/4, 7/8 (Pragmatic Trellis)	
Roll Off Factor:	α = 0,25 or α = 0,35		
Transport Stream Input Interface:	DVB-SPI (DSUB25 female) DVB-ASI-electrical (Connector BNC female 50 Ohm, Impedance 75 Ohm) DVB-ASI-optical (Connector ST female, Multimode, 1300 nm) (Option)		
Transport Stream Frames Size:	188 bytes or 204 bytes		
Packet Stuffing:	Null packet insertion, when the transmission rate is higher than the data rate of the data input.		
Transport Stream Adaption and Randomization:	Compliant with EN 300421		
Convolutional Interleaving:	Depth I =12		
Compliant with DVB Standards:	EN 300421EN 301210 (8PSK, 16QAM, α = 25 %) EN 50083-9 (ASI electrical, SPI Interface)		
Monitoring:	Faults, stored faults with time stamps		
Monitoring and Control Interface:	TCP/IP over Ethernet (10 or 100 Mbit/s, auto sensing) RS232 or RS422/RS485 (Connectors DSUB09 female) (configurable by software) Mute Input: TTL logic input with internal pull up		
Alarm Interface:	Two potential free contacts (DPDT, Connector DSUB09 female)		
Temperature Range:	HDM: -30°C to 60°C operating (10 minutes warm up at -30°C) SDM: 0°C to 50°C operating -30°C to 80°C storage		
Relative Humidity:	< 95% non condensing		
User Interface:	SDM: LCD-Display 2 x 40 characters, 4 cursor keys, 4 function keys HDM: VFD-Display 2 x 40 characters, 4 cursor keys, 4 function keys		
Power Supply:	85...264 V AC, 40...70 Hz		
Mains Fuse:	2 x 3.15 A time-lag fuse		
Dimension and Weight:	483 x 44 x 500 mm ³ , 1 RU (19") appr. 8.3 kg		
Order Information:	HDM-[Output Band]-[IF Imp]-[Firmware Opt.] or SDM-[Output Band]-[IF Imp]-[Firmware Opt.] Example: SDM-V-75-PL or HDM-L-50-QH		

Specifications are subject to change

Single / Dual / Triple Band Block-Upconverter L-Band to C, X, Ku-Band



Module

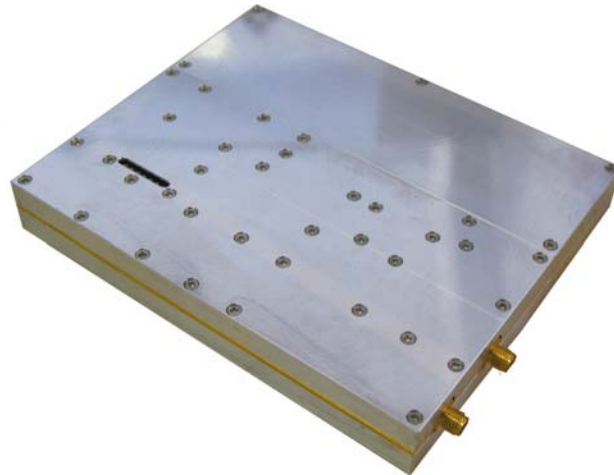

**PRELIMINARY
Device**

The new BUC series of Work Satcom sets higher standards in modern Block Converter technology. High integrated circuits provide most reliable and extremely compact design with very little power consumption and good phase noise. DRO's and other critical parts are replaced by MMIC's. All BUC's are equipped with internal gain control. A built in controller provides an interface to external M&C systems.

Due to the lightweight rugged design, not critical against shock and vibrations, mini-buc's can be implemented almost everywhere, e.g. in TWTA's and SSPA's for mobile Land-, Sea- and Airborne systems.

Work Satcom BUC's are also available within a standard 19" rack mount housing for Satellite news gathering equipment (SNG) and mobile satellite communication equipment (Fly-Aways).

KEY FEATURES

- High integrated MMIC technology
 - Low phase noise
 - Optional internal OCXO with long term stability 10^{-7} / year
 - Output power +10 dBm (1dB compression point)
 - Low spurious emissions
 - Low power consumption typ. less than 10 W
 - Operating temperature range up to -30°C to +60°C
 - Remote control (RS232 or RS422/485) (optional)
 - Packet command syntax supports 2-wire or 4-wire bus systems and allows addressed operation
 - Summary alarm output (change over switch contact)
 - Transmit mute input
 - Adjustable gain control (range: 15 dB)
 - Cascade able to multi converter configurations
- High reliability, Low cost

Single Band / Dual Band / Triple Band L-Band Block Upconverter Specification High Performance Type (H..) and Standard Type (S..), Module			
Triple Band Type:	HCUB-CXKu_x-M		
Dual Band Type:	HCUB-CX-M, HCUB-CKu_x-M or HCUB-XKu_x-M		
Single Band Type:	HCUB-C-M / SCUB-C-M, HCUB-X-M / SCUB-X-M, HCUB-Ku_x-M / SCUB-Ku_x-M		
RF-Output Frequency:	C-Band 5.850...6.425 GHz	X-Band 7.9...8.4 GHz	Ku-Band Ku ₁ : 13.75...14.50 GHz Ku ₂ : 14.00...14.50 GHz Ku ₃ : 12.75...13.50 GHz (on request)
Conversion Scheme:	Block upconversion, no frequency inversion		
IF-Input Characteristics:	Frequency: Impedance: Return Loss: Connector:	950 MHz...1525 MHz (C-Band) 950 MHz...1450 MHz (X-Band) 950 MHz...1700 MHz (Ku-Band) 50 Ω 15 dB max. (VSWR 1.43:1) SMA (female)	
RF-Output Characteristics:	Impedance: Return Loss: 1 dB Compression Point: Output Muting: Connectors:	50 Ω 15 dB max (VSWR 1.43:1) 10 dBm -75 dBc min (by command or sense input or by alarm condition) SMA (female)	
Transfer Characteristics:	Max Conversion Gain: Attenuation range: Gain Variation over Temp.: Gain Flatness over Freq.: Gain Flatness over 40 MHz: Gain Stability: Image Rejection: Noise Figure:	25 dB ± 2 dB max. over frequency and temperature 0...15 dB, 0.1 dB steps ± 1 dB max 1.5 dB max. over band (C, X or Ku) ± 0.5 dB 0.25 dB 80 dB min. 10 dB max.	
Specs of External Reference	Frequency: Level: Phase Noise @ 100 Hz 1 kHz 10 kHz 100 kHz	10 MHz sine wave 0 dBm min. via IF input coax -140 dBc/Hz max. -150 dBc/Hz max. -160 dBc/Hz max. -160 dBc/Hz max.	
LO Phase Noise with external reference	10 Hz 100 Hz 1 kHz 10 kHz 100 kHz 1 MHz RMS (10 Hz...100 kHz)	- 51 dBc/Hz max. - 63 dBc/Hz max. - 73 dBc/Hz max. - 83 dBc/Hz max. - 93 dBc/Hz max. -102 dBc/Hz max. 1.51°	
Spurious Outputs:	Signal related: Signal independent:	-65 dBc max. within RF band -70 dBm max. within RF band	
Intermodulation (3rd Order):	53 dBc @ two equal tone carrier , 5 MHz distance: P _{in} 2 x -33 dBm, P _{out} : 2 x -8 dBm)		
Internal frequency Stability: (option)	± 1 x 10 ⁻⁷ , 0°C to 50°C ± 2 x 10 ⁻⁸ , 0°C to 50°C (after 30 min warm up) ± 5 x 10 ⁻⁹ per day (fixed temperature after 24 h warm up)		
Monitoring and Control Interface:	RS232, RS422/RS485 (optional)		
Out of lock indicator:	Open Collector (shorted to ground when unlocked) Automatic muting when unlocked		
Temperature Range:	SCUB: 0°C to +50°C max. operating HCUB: -30°C to +60°C max. operating -46°C to +73°C max. storage		
Relative Humidity:	< 95 % non condensing		
Power Supply, Consumption	12...24 V DC, 10 W optional: fed from IF input coax or external connector		
Dimension and Weight:	L x W x H: 140 x 100 x 15 mm (without connectors), 0,3 kg (approx.)		
Altitude:	15,000 feet max		

Order Information:	HCUB-[RF Band]-M or SCUB-[RF Band]-M Example: HCUB-CXKu-M or HCUB-CKu-M or SCUB-Ku-M
---------------------------	---

Specifications are subject to change

Single / Dual / Triple Band Block-Upconverter L-Band to C, X, Ku-Band



Outdoor Version

**PRELIMINARY
Device**



The new BUC series of Work Satcom sets higher standards in modern Block Converter technology. High integrated circuits provide most reliable and extremely compact design with very little power consumption and good phase noise. DRO's and other critical parts are replaced by MMIC's. All BUC's are equipped with internal gain control. A built in controller provides an interface to external M&C systems.

Due to the lightweight rugged design, not critical against shock and vibrations, mini-bug's can be implemented almost everywhere, e.g. in TWTA's and SSPA's for mobile Land-, Sea- and Airborne systems.

Work Satcom BUC's are also available within a standard 19" rack mount housing for Satellite news gathering equipment (SNG) and mobile satellite communication equipment (Fly-Aways).

OUTDOOR INSTALLATION

The units are designed for outdoor use, to be mounted directly behind the antenna. They do not require additional protection. The housing provides environmental protection according to IP67 (temporary flooding) when all cables are connected and sealed appropriately. The special environmental protection sleeves for the coaxial connectors allow optimal sealing from the housing to the cable. The housing should be mounted with the connector side down. Alternatively the connector panel can be in a vertical position.

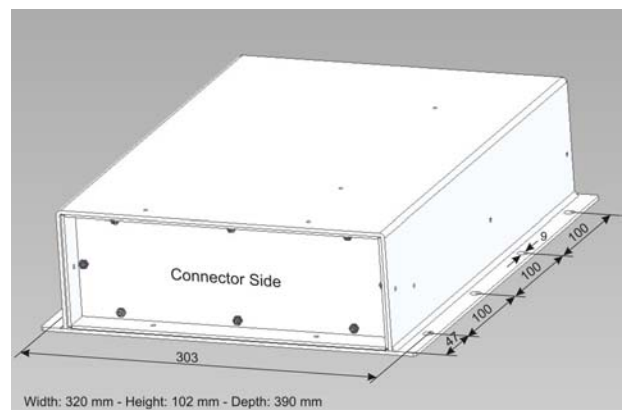

Single Band / Dual Band / Triple Band L-Band Block Upconverter Specification High Performance Type (H..) and Standard Type (S..), Module			
Triple Band Type:	HCUB-CXKu_x-OD		
Dual Band Type:	HCUB-CX-OD, HCUB-CKu_x-OD or HCUB-XKu_x-OD		
Single Band Type:	HCUB-C-OD, HCUB-X-OD, HCUB-Ku_x		
RF-Output Frequency:	C-Band 5.850...6.425 GHz	X-Band 7.9...8.4 GHz	Ku-Band Ku ₁ : 13.75...14.50 GHz Ku ₂ : 14.00...14.50 GHz Ku ₃ : 12.75...13.50 GHz (on request)
Conversion Scheme:	Block upconversion, no frequency inversion		
IF-Input Characteristics:	Frequency: Impedance: Return Loss: Connector:	950 MHz...1525 MHz (C-Band) 950 MHz...1450 MHz (X-Band) 950 MHz...1700 MHz (Ku-Band) 50 Ω 15 dB max. (VSWR 1.43:1) SMA (female)	
RF-Output Characteristics:	Impedance: Return Loss: 1 dB Compression Point: Output Muting: Connectors:	50 Ω 15 dB max (VSWR 1.43:1) 10 dBm -75 dBc min (by command or sense input or by alarm condition) SMA (female)	
Transfer Characteristics:	Max Conversion Gain: Attenuation range: Gain Variation over Temp.: Gain Flatness over Freq.: Gain Flatness over 40 MHz: Gain Stability: Image Rejection: Noise Figure:	25 dB ± 2 dB max. over frequency and temperature 0...15 dB, 0.1 dB steps ± 1 dB max 1.5 dB max. over band (C, X or Ku) ± 0.5 dB 0.25 dB 80 dB min. 10 dB max.	
Specs of External Reference	Frequency: Level: Phase Noise @ 100 Hz 1 kHz 10 kHz 100 kHz	10 MHz sine wave 0 dBm min. via IF input coax -140 dBc/Hz max. -150 dBc/Hz max. -160 dBc/Hz max. -160 dBc/Hz max.	
LO Phase Noise with external reference	10 Hz 100 Hz 1 kHz 10 kHz 100 kHz 1 MHz RMS (10 Hz...100 kHz)	- 51 dBc/Hz max. - 63 dBc/Hz max. - 73 dBc/Hz max. - 83 dBc/Hz max. - 93 dBc/Hz max. -102 dBc/Hz max. 1.51°	
Spurious Outputs:	Signal related: Signal independent:	-65 dBc max. within RF band -70 dBm max. within RF band	
Intermodulation (3rd Order):	53 dBc @ two equal tone carrier , 5 MHz distance: P _{in} 2 x -33 dBm, P _{out} : 2 x -8 dBm)		
Internal frequency Stability: (option)	± 1 x 10 ⁻⁷ , 0°C to 50°C ± 2 x 10 ⁻⁸ , 0°C to 50°C (after 30 min warm up) ± 5 x 10 ⁻⁹ per day (fixed temperature after 24 h warm up)		
Monitoring and Control Interface:	RS232, RS422/RS485 (optional)		
Out of lock indicator:	Open Collector (shorted to ground when unlocked) Automatic muting when unlocked		
Temperature Range:	SCUB: 0°C to +50°C max. operating HCUB: -30°C to +60°C max. operating -46°C to +73°C max. storage		
Relative Humidity:	< 95 % non condensing		
Power Supply, Consumption	12...24 V DC, 10 W optional: fed from IF input coax or external connector		
Mains Power Input:	Amphenol: C16-1 male		
Dimension and Weight:	L x W x H: 390 x 102 x 320 mm ³ , appr. 5 kg		
Altitude:	15,000 feet max		
Degree of Protection	IP 67 (acc. IEC 529)		
Order Information:	HCUB-[RF Band]-OD Example: HCUB-CXKu-OD or HCUB-CKu-OD		

Specifications are subject to change

Redundancy Switch (1:1)



The Work Redundancy Switch is used for 1:1 redundancy configurations for upconverters, downconverters, DVB modulator-upconverters, LNAs or even HPAs. They include typically a coaxial signal splitter for the input signal and a coaxial signal switch for the output signal. External waveguide transfer switches can also be connected. DC power to LNAs can be provided.

The unit can be set in automatic mode, where an automatic switchover to the stand by unit is performed upon detection of an alarm of the active unit. Also a manual switchover to the standby unit can be initiated.

The units can be controlled from the front panel or remotely via RS 232, RS422/485 or IP over Ethernet.

Two power supplies and two AC input connectors guarantee very high availability of the unit.

Redundancy Switch 1:1 Type RSCM1									
Switching:	Manual or Automatic								
Alarm Interface to Converter Units:	2 Interfaces to sense contact closures at alarm outputs of converter units (Connectors DSUB15 female)								
Signal Splitter:	<table border="0"> <tr> <td>Frequency range:</td> <td>6...18 GHz (RSCM1-50K-xx) 4...8 GHz (RSCM1-50C-xx)</td> </tr> <tr> <td>Connectors:</td> <td>5...300 MHz (RSCM1-50V-xx, RSCM1-75V-xx) SMA female (RSCM1-50K-xx, RSCM1-50C-xx) BNC female (RSCM1-50V-xx, RSCM1-75V-xx)</td> </tr> <tr> <td>Return loss:</td> <td>>14 dB (RSCM1-50K-xx) >15 dB (others)</td> </tr> <tr> <td>Attenuation:</td> <td>1.2 dB max above 3 dB (RSCM1-50K-xx, RSCM1-50C-xx) 1.0 dB max above 3 dB (RSCM1-50V-xx, RSCM1-75V-xx)</td> </tr> </table>	Frequency range:	6...18 GHz (RSCM1-50K-xx) 4...8 GHz (RSCM1-50C-xx)	Connectors:	5...300 MHz (RSCM1-50V-xx, RSCM1-75V-xx) SMA female (RSCM1-50K-xx, RSCM1-50C-xx) BNC female (RSCM1-50V-xx, RSCM1-75V-xx)	Return loss:	>14 dB (RSCM1-50K-xx) >15 dB (others)	Attenuation:	1.2 dB max above 3 dB (RSCM1-50K-xx, RSCM1-50C-xx) 1.0 dB max above 3 dB (RSCM1-50V-xx, RSCM1-75V-xx)
Frequency range:	6...18 GHz (RSCM1-50K-xx) 4...8 GHz (RSCM1-50C-xx)								
Connectors:	5...300 MHz (RSCM1-50V-xx, RSCM1-75V-xx) SMA female (RSCM1-50K-xx, RSCM1-50C-xx) BNC female (RSCM1-50V-xx, RSCM1-75V-xx)								
Return loss:	>14 dB (RSCM1-50K-xx) >15 dB (others)								
Attenuation:	1.2 dB max above 3 dB (RSCM1-50K-xx, RSCM1-50C-xx) 1.0 dB max above 3 dB (RSCM1-50V-xx, RSCM1-75V-xx)								
Signal Switch:	<table border="0"> <tr> <td>Frequency Range:</td> <td>Transfer Relay 0...18 GHz, 50 ohms</td> </tr> <tr> <td>Connectors:</td> <td>SMA female</td> </tr> <tr> <td>Return loss:</td> <td>> 15 dB</td> </tr> <tr> <td>Attenuation:</td> <td>0,5 dB max</td> </tr> </table>	Frequency Range:	Transfer Relay 0...18 GHz, 50 ohms	Connectors:	SMA female	Return loss:	> 15 dB	Attenuation:	0,5 dB max
Frequency Range:	Transfer Relay 0...18 GHz, 50 ohms								
Connectors:	SMA female								
Return loss:	> 15 dB								
Attenuation:	0,5 dB max								
Remote M&C Interface:	RS232 or RS422/RS485 (Connector DSUB09 female) Ethernet/IP (10 or 100 Mbit/s, auto sensing)								
Summary Alarm Interface:	Two potential free contacts (DPDT, Connector DSUB09 female)								
Internal M&C Interface:	RS485 (Connector DSUB09 male)								
Configuration:	16 DIP switches on rear side / serial interface								
Temperature Range:	-30°C to 60°C operating -30°C to 80°C storage								
Relative Humidity:	< 95 % non condensing								
User Interface:	10 LEDs, 4 Function Keys								
Power Input:	85...264 V AC, 40...70 Hz 0,9 A max Redundant Power Supply								
Power Consumption:	typical 5 W / 10 VA								
Mains Fuse:	2 x 3.15 A time-lag (per power supply unit)								
Dimension and Weight:	483 x 44 x 270 mm ³ , 1 RU (19") appr. 3 kg								

Order Information	RSCM1-[Signal Splitter]-50 Example: RSCM1-75V-50 or RSCM1-50K-50
--------------------------	---

Specifications are subject to change

EXAMPLES FOR REDUNDANCY CONFIGURATIONS

WORK upconverters, downconverters or modulator-upconverters support many different types of configurations for 1:1 or for N:1 redundancy systems.

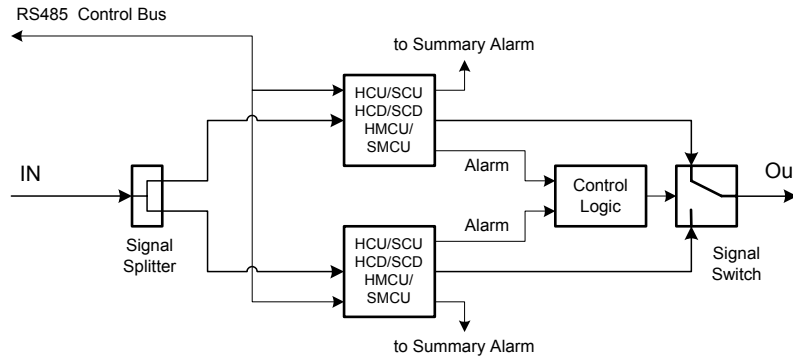

Figure 1: 1 to 1 Redundancy with Signal Switch on the Output

Figure 1 shows a very effective 1:1 redundancy with a signal switch at the output. This solution provides proper switchover from one unit to the other and introduces only minimum additional signal attenuation. Redundancy sets are available which include an

appropriate signal switch for the IF or the RF, the control logic, an IF, RF or base-band signal splitter and the cabling. Also signal switches on the input can be provided.

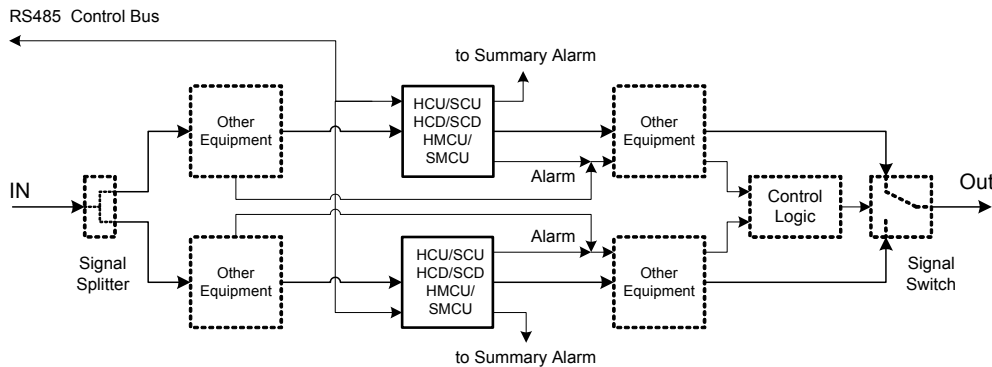

Figure 2: 1 to 1 Redundancy Chain together with other Equipment

Figure 2 shows a redundancy chain where the switchover is performed by the last stage of the chain. In these cases one of the two alarm relay outputs can

be connected to an alarm input of the following unit in the chain.

Redundancy Switch System (N:1)



The Work Redundancy Switch System N:1 can be configured for redundancy configurations with maximum 8 main units and one spare unit. The redundancy system can be used for upconverters, downconverters, DVB modulator-upconverters, LNAs and even HPAs . The core of the solution is a highly flexible control unit. The required coaxial transfer switches, waveguide transfer switches or signal splitters are mounted on separate panels or within an outdoor housing. Switching devices can be added in a highly modular way to the system if the number of required channel increases over time.

The switching system can be set in automatic mode, were an automatic switchover to the spare unit is performed upon detection of an alarm of the main unit. Also a manual switchover to the spare unit and back can be initiated.

Two power supplies and two AC input connectors within the controller unit guarantee very high availability.

Also DC power to LNAs can be provided, if required.

The system can be configured from the front panel of the controller or remotely via RS232, RS422/485 or IP over Ethernet.

N:1 Redundancy Switch Specification Type RSCMN	
Monitoring and Control Interface:	RS232 or RS422/RS485 (Connector DSUB09 female) Ethernet/IP (10 or 100 Mbit/s, auto sensing)
Temperature Range:	-30°C to 60°C operating (the LCD display is operational: -20°C to 60°C) -30°C to 80°C storage
Relative Humidity:	< 95% non condensing
User Interface:	LCD, 2 x 40 characters, 4 cursor keys, 2 function keys
Power Supply:	85...264 V AC, 40...70 Hz 0.9 A max
Dimension and Weight:	483 x 44 x 270 mm ³ , 1 RU (19") appr. 4 kg

Order Information	RSCMN-[Input Splitter Imp]-[Output Switch Imp]-[OD (Outdoor Unit)] Example: RSCM1-75-50
--------------------------	--

Specifications are subject to change

Redundancy Switch System (1:1) Outdoor Version - Controller



The 1:1 redundancy is also available in an outdoor version, where the signal splitter and the signal transfer relay is mounted within an outdoor switch box. The control unit is similar to the indoor redundancy controller, but the mentioned

components before are omitted within the control unit. The outdoor switch box also includes interfaces for alarms and M&C of outdoor units. A control cable runs from the outdoor switch box to the indoor redundancy controller.

Redundancy Switch Controller 1:1 Type RSCM1-OD	
Switching:	Manual or Automatic
Control Interface to Outdoor Switch Box RSB1-xxx-xx:	Alarm inputs, control outputs (Connector DSUB15 female)
Remote M&C Interface:	RS232 or RS422/RS485 (Connector DSUB09 female) Ethernet/IP (10 or 100 Mbit/s, auto sensing)
Summary Alarm Interface:	Two potential free contacts (DPDT, Connector DSUB09 female)
Internal M&C Interface:	RS485 (Connector DSUB09 male)
Configuration:	16 DIP switches on rear side / serial interface
Temperature Range:	-30°C to 60°C operating -30°C to 80°C storage
Relative Humidity:	< 95 % non condensing
User Interface:	10 LEDs, 4 Function Keys
Power Input:	85...264 V AC, 40...70 Hz 0.9 A max Redundant Power Supply
Power Consumption:	typical 5 W / 10 VA
Mains Fuse:	2 x 3.15 A time-lag (per power supply unit)
Dimension and Weight:	483 x 44 x 270 mm ³ , 1 RU (19") appr. 3 kg

Order Information:	RSCM1-OD
---------------------------	-----------------

Specifications are subject to change

Redundancy Switch System (1:1) Outdoor Version – Switch Box



Outdoor Redundancy Switch Box 1:1 Type RSB1-xxx-50		
Control Interface to Indoor Control Unit RSCM1-OD:	Alarms, control signals (Connector Type: MIL-C-26482: MS 3120 E 14-19 S)	
Alarm Interface to Converter Units:	2 Interfaces to sense contact closures at alarm outputs of converter units and for internal M&C (RS485) (Connector Type: MIL-C-26482: MS 3120 E 12-8 S)	
Signal Splitter:	Frequency range:	6...18 GHz (RSB1-50K-xx) 4...8 GHz (RSB1-50C-xx) 5...300 MHz (RSB1-50V-xx, RSB1-75V-xx)
	Connectors:	N female
	Return loss:	>14 dB (RSB1-50K-xx) >15 dB (others)
	Attenuation:	1.2 dB max above 3 dB (RSB1-50K-xx, RSB1-50C-xx) 1.0 dB max above 3 dB (RSB1-50V-xx, RSB1-75V-xx)
Signal Switch:	Frequency Range:	Transfer Relay 0...18 GHz, 50 ohms
	Connectors:	N female
	Return loss:	> 15 dB
	Attenuation:	0.5 dB max
Temperature Range:	-30°C to 60°C operating -30°C to 80°C storage	
Relative Humidity:	100 %	
Dimension and Weight:	190 x 190 x 100 mm appr. 3 kg	
Degree of Protection:	IP 67 (acc. IEC 529)	

Order Information:	RSB1-[Signal Splitter]-50 Example: RSB1-50C-50 or RSB1-75V-50
---------------------------	--

Specifications are subject to change

Redundancy Switch System (2:1) Outdoor Version – Switch Box



The Picture shows an example of outdoor housing with a 2:1 redundant switching system. The switching unit is connected to the control unit, which is installed indoor. Within the outdoor switching unit alarm and status indication via LEDs, manual switchover and

easy access to the serial control interfaces of the controlled units is possible. The picture below shows a typical 2:1 configuration with upconverters, built as outdoor solution.

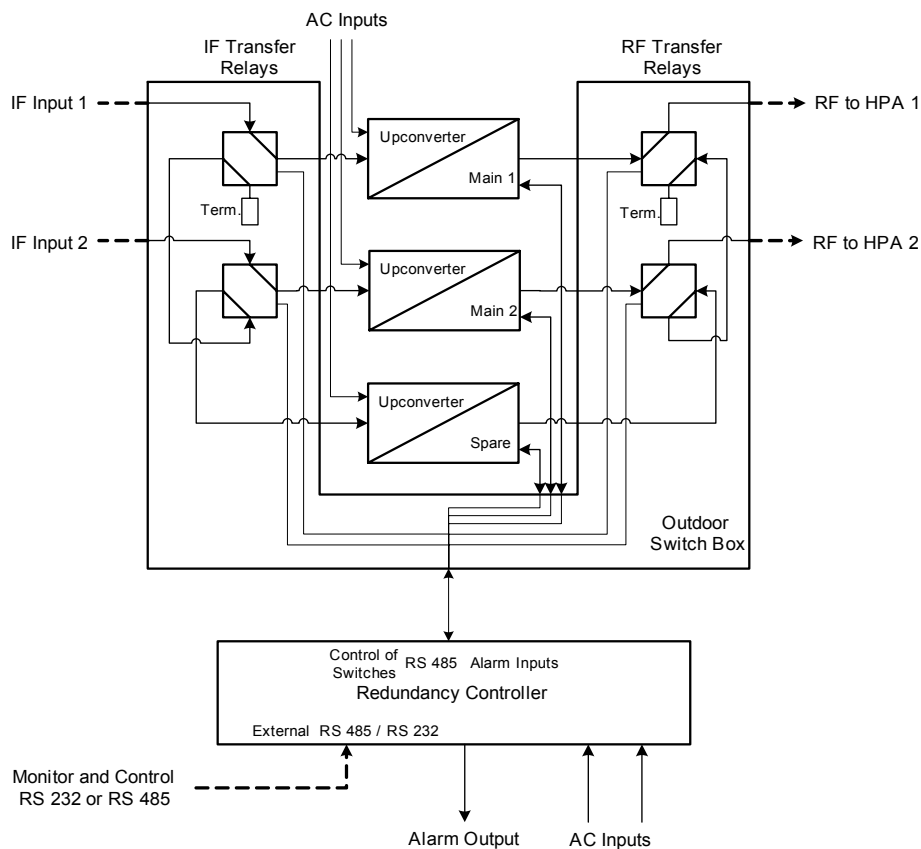

Remote Control Unit



This remote control unit is mainly useful for remote control of outdoor converter units. The unit is powered remotely from the outdoor unit. The front panel allows to manually control the configuration of an outdoor converter in a similar way as it is possible for indoor converter units.

Additionally further remote control via RS232, RS485 or IP over Ethernet is possible through this control unit, also additional alarm relay outputs are provided.

A software option allows to provide uplink power control for upconverters. This requires an additional external beacon receiver. The DC output and the alarm output of a beacon receiver is connected in this case to the control unit (see next page).

As option this unit is also available for standard rack mount converters. In this case the unit includes a separate power supply.

Remote Control Unit	
Monitoring and Control Interface:	RS232 or RS422/RS485 (Connectors DSUB09 female) (selectable by customer), IP over Ethernet
Temperature Range:	-30°C to 60°C operating (the LCD display is operational: -20°C to 60°C) -30°C to 80°C storage
Relative Humidity:	< 95% non condensing
User Interface:	LCD, 2 x 40 characters, 4 cursor keys, 2 function keys
Power Supply:	85...264 V AC, 40...70 Hz 0.9 A max
Dimension and Weight:	483 x 44 x 270 mm ³ , 1 RU (19") appr. 4 kg

Order Information	RC-CO-[Control Type] Example: RC-CO-HCU or RC-CO-HCD
--------------------------	---

Specifications are subject to change

Uplink Power Control



The Uplink Power Control is a hardware and software option to the control panel for the upconverter outdoor versions. This control panel can also be used together with upconverter indoor versions. Besides the uplink power control this control panel allows also remote control of the upconverter.

The Uplink Power Control senses a DC signal from a beacon receiver. If due to additional atmospheric attenuation caused by rain, snow, clouds or fog or also due to antenna misalignment the beacon signal is attenuated, the transmitted signal is increased proportionally until a configurable maximum additional gain is reached or the maximum gain of the upconverter is reached.

The uplink power control has the following interface for the DC signal from the beacon receiver:

Connector type: BNC, 50 Ohm, female
Impedance: tbd
DC voltage range: tbd

Optional input signals:

Input for lock signal from the beacon receiver (tbd)
Input for alarm signal from the beacon receiver (tbd)

The following parameters can be configured:

- Uplink power control on/off
- Maximum gain increase in reference to clear sky gain
- Sampling and update period in seconds
- Ratio between decrease of beacon signal and increase of transmission signal (due to difference of rain attenuation effect for different frequencies)
- Up to 5 DC values for beacon signal strength can be entered as reference points for linear interpolation (characteristic of beacon receiver).
- Clear sky value of DC beacon receiver signal
- Sustain period in seconds (up 3600 seconds) for which the uplink power control keeps the last gain increase value (in case of deep fade conditions where the beacon receiver can loose lock for some period of time).

The following parameters can be monitored:

- DC signal from beacon receiver
- Calculated attenuation of beacon signal
- Actual gain increase of transmission signal (theoretical value only if the uplink power control mode is off)

WORK SATCOM

**Raiffeisenstr. 12
D-83607 Holzkirchen
Germany
phone: +49 (0)8024 6408 - 0
fax: +49 (0)8024 6408 - 40**

**e-mail: sales@work-gmbh.de
web: www.work-gmbh.de**



DIN EN ISO 9001:2000
Zertifikat Nr. 20 100 42000758
www.tuv.at